

Westchester Homeowner Weatherization Projects



NYSERDA and Con Edison Coordinated Incentive Program

In Westchester County, Consolidated Edison (Con Edison) and the New York State Energy Research and Development Authority (NYSERDA) have come together to make energy upgrades more affordable for homeowners. This partnership aims to increase customer demand for energy upgrades driving an increase in business for our participating contractor network. Together, Con Edison's Weather Ready Program and NYSERDA's Comfort Home Program will pilot deeper retrofit projects through expanded homeowner incentives and contractor heat pump referral incentives.

To minimize confusion and ease the administrative burden in Westchester, Con Edison partnered with ICF to process all residential weatherization projects for aggregators and contractors in their electric and gas service territories.

Who is Eligible?

Single family homes or multifamily buildings (2-4 dwelling units) are eligible if they have one of the following:

- Con Edison electric for heating (including heat pumps)
- Con Edison natural gas for heating
- A delivered fuel (fuel oil or propane) for heating and Con Edison electricity for any AC system.

If the home does not meet the Con Edison eligibility above, and is in Westchester County, NYSERDA will pay an additional Westchester Incentive on top of any NYSERDA Comfort Home Package Incentives.

Customers are encouraged to convert to a heat pump as a home heating solution in conjunction with weatherization work, or after weatherization work is completed. An incentive is available to contractors who refer customers to install a heat pump within 24 months of the weatherization project.

Comfort Home Westchester Incentive

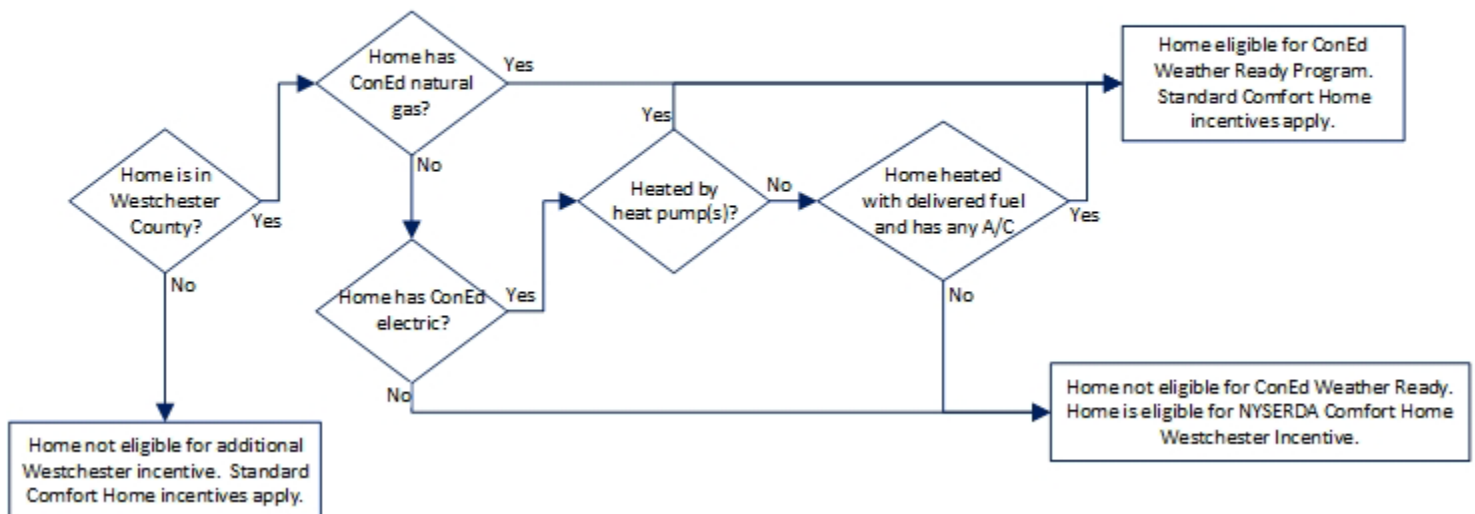

Program Details

The following Con Edison Weather Ready and NYSERDA Comfort Home incentives may both be applicable for projects in Westchester County that meet the respective program eligibility requirements.

Con Edison Weather Ready:

Eligible Con Edison customers are eligible for an incentive paid by Con Edison for load reduction installations that include the installation of insulation and air sealing improvements. See the Con Edison Weather Ready Guide for a full list of eligible measures and homeowner/contractor facing incentives.

NYSERDA Comfort Home:

Westchester customers are eligible for incentives from NYSERDA’s Comfort Home Program based on the measure package installed. These incentives are customer incentives; therefore, the contractor must subtract them from the total project cost in the contract. NYSERDA will issue payment directly to the contractor.

Contractors should submit projects directly to NYSERDA’s Comfort Home Program and NYSERDA will notify contractors if the project also qualifies for the Con Edison Weather Ready. Contractors will then be required to submit additional required documentation to ICF, who will administer the Con Edison Weather Ready Incentive for eligible customers in Westchester County.

Comfort Home Heat Pump Referrals:

NYSERDA offers a heat pump referral incentive to contractors who convert to a heat pump as a home heating solution in conjunction with load reduction work, or after load reduction work is completed in a separate sales agreement at a later date from the load reduction work. In all cases, a heat pump eligible under the NYS Clean Heat Program must be installed within 24 months of the project completion date.

NYSERDA Comfort Home Incentives:

Load Reduction Incentives from NYSERDA			Heat Pump Referral Incentives	
Packages	ConEd Eligible	Not ConEd Eligible	Packages	
Package A	\$1,600 + ConEd Incentive	\$2,600	After Package A	\$1,000
Package B	\$3,000 + ConEd Incentive	\$4,000	After Package B	\$1,500
Package C	\$4,000 + ConEd Incentive	\$5,000	After Package C	\$2,000

Project Eligibility and Submission Requirements

NYSERDA Comfort Home Incentives	Con Edison Weather Ready Incentives
Required Documents	
<p>Pre-Installation:</p> <ul style="list-style-type: none"> • NYSERDA Utility Release Form, signed by customer • NYSERDA Owner Services Agreement (required only for projects commissioned by renters/tenants) 	<p>Pre-Installation:</p> <ul style="list-style-type: none"> • Customer agreement, including a scope of work • Pre-Installation photo set (Con Edison Program Guide details examples)
<p>Post Installation:</p> <ul style="list-style-type: none"> • Project scope of work “Customer Contract”, signed by customer, incentive deducted from project total cost 	<p>Post Installation:</p> <ul style="list-style-type: none"> • Project Submission Checklist • Completed form “Signature Packet” signed by customer and contractor Including customer COVID-19 Precautionary Acknowledgment, Home Assessment Checklist, signed by customer and contractor • Project scope of work “Customer Contract,” signed by customer and contractor; incentive deducted from project total cost, areas addressed, quantities (sq. ft, etc.) • Post Installation Photo set (Con Edison Program Guide provides example) • If blower door test was conducted include blower door test in and test out photos of manometer
Where to Submit	
<ul style="list-style-type: none"> • Submit all projects to NYSERDA’s Compass Platform https://hpr.buildingperformance.com • Upload NYSERDA Utility Release Form to contractor company’s Document Library on NYSERDA Comfort Home SharePoint 	<ul style="list-style-type: none"> • Submit all pre-approved projects and supporting documentation to Con Edison’s Weather Ready Program – Online Intake Tool: https://coned-weatherization.programprocessing.com
Submission Process	
<p>Prior to Installation:</p> <ul style="list-style-type: none"> • Upload the signed Utility Release Form to SharePoint • Submit Assessment using Compass Platform <ul style="list-style-type: none"> - NYSERDA will notify the contractor when the assessment and \$150 incentive has been approved. 	<p>Prior to Installation:</p> <ul style="list-style-type: none"> • Submit required “Pre-Installation” documents to ICF through your contractor company’s secured Weather Ready OneDrive folder <ul style="list-style-type: none"> - ICF will notify contractors or aggregators the project has been pre-approved.
<p>Post Installation:</p> <ul style="list-style-type: none"> • Upload the Customer Contract to the Document Management Section of Compass • Submit Install using Compass Platform <ul style="list-style-type: none"> - NYSERDA will notify the contractor the install has been approved and Package incentives will be paid upon approval. 	<p>Post Installation:</p> <ul style="list-style-type: none"> • Submit Required “Post Installation” documents to ICF via Con Edison Weather Ready Program – Online Intake Tool: https://coned-weatherization.programprocessing.com <ul style="list-style-type: none"> - ICF will notify the contractor the project has been approved, the RWP Incentives and Performance Incentives (if applicable) will be paid upon approval.