

Summary of Operations:  
**FLEET DEMONSTRATION OF  
SHOREPOWER TRUCK ELECTRIFIED PARKING  
ON THE I-87 NORTHWAY**  
Final Report



Prepared for  
**THE NEW YORK STATE ENERGY RESEARCH AND  
DEVELOPMENT AUTHORITY**  
Albany, New York  
Joseph D. Tario, P.E.  
Project Manager

Prepared by  
**ANTARES GROUP INC.**  
Landover, Maryland  
Chris Lindsey

In Association with  
**SHUREPOWER L.L.C.**  
Rome, New York  
Jeff Kim

NYSERDA Agreement Number 7209

December 2005

## NOTICE

This report was prepared by Antares Group Inc. (hereafter “Antares” or “the Contractor”) in the course of performing work contracted for and sponsored by the New York State Energy Research and Development Authority (hereafter “NYSERDA”), New York State Department of Transportation (hereafter “NYSDOT”), and Oak Ridge National Laboratory (hereafter “ORNL” or collectively “the Sponsors”). The opinions expressed in this report do not necessarily reflect those of the Sponsors or the State of New York, and reference to any specific product, service, process, or method does not constitute an implied or expressed recommendation or endorsement of it. Further, the Sponsors and the State of New York make no warranties or representations, expressed or implied, as to the fitness for particular purpose or merchantability of any product, apparatus or service, or the usefulness, completeness, or accuracy of any processes, methods, or other information contained, described, disclosed, or referred to in this report. The Sponsors, the State of New York, and the contractor make no representation that the use of any product, apparatus, process, method, or other information will not infringe privately owned rights and will assume no liability for any loss, injury, or damage resulting from, or occurring in connection with, the use of information contained, described, disclosed, or referred to in this report.

This report was prepared by the Contractor based on preliminary operational data provided by Shurepower, LLC (hereafter “Shurepower” or “Subcontractor”). Antares has not verified the accuracy of the data reported by the Subcontractor. Therefore, conclusions drawn from this report should not be represented as precise and should be construed as an evaluation of the available data.

## ABSTRACT

This report contains a summary of activities completed by the Contractor over the course of nearly three years, primarily in the Albany, New York area along the Northway (I-87). The goal of the project was to demonstrate the benefits and cost effectiveness of shore power truck electrified parking (TEP) as a long-term solution to heavy-duty truck idling. Activities included retrofitting a sleeper cab with the appropriate shore power heating, ventilation and air conditioning (HVAC) system and other convenience items to enhance the shore power experience. Additionally, a shore power facility was constructed in Wilton, New York that includes a monitoring and control system. The system developed by Shurepower, allows drivers to connect to an electrical outlets (receptacles) by swiping a magnetically encoded user card and entering the desired parking space number at the payment kiosk. The system was designed to monitor utilization parameters including time of use, energy used, user identification, and weather.

Parameters recorded and reported by the Subcontractor included: system hours of use, number of users, energy consumption, and ambient weather conditions. Antares used data provided by the Subcontractor to analyze the operations at the Wilton Travel Plaza. Operating issues were identified, benefits were quantified and results were documented in monthly reports. In addition, sufficient operational experience was gained to recommend future activities to help increase utilization and expand shore power TEP infrastructure.

**Key words:** Heavy-duty truck sleeper cab idling, Truck Stop Electrification, TSE, shore power, Shurepower, Truck Electrified Parking, TEP, idle-reduction, anti-idling, hours of service, HOS

## **ACKNOWLEDGEMENT**

Antares would like to extend their sincere gratitude towards the New York State Energy Research and Development Authority, New York State Department of Transportation, and the United States Department of Energy, managed on their behalf by Oak Ridge National Laboratory, for providing funding for the I-87 demonstration project. This collaborative effort provided the basis for the successful completion of this progressive demonstration project. Antares would also like to thank Shurepower for supplying the hardware and operational data to enable the completion of this report.

Antares would like to individually thank the following pioneers for having the foresight and leadership to help deploy pre-commercial idle reduction technologies in the State of New York: Joseph Tario and Richard Drake of NYSERDA, Katey Lenox of ORNL, and Colleen Hagen of NYSDOT. Together, their dedication and efforts have helped reduce truck idling emissions, noise and fuel consumption, resulting in safer highways and cleaner air.

## TABLE OF CONTENTS

SUMMARY .....	S-1
Section 1 - INTRODUCTION .....	1-1
Section 2 - PROJECT EXECUTION .....	2-1
PROJECT OVERVIEW .....	2-1
SCOPE OF WORK.....	2-1
PHASE I TASKS.....	2-2
Task 0.0: Kick-Off Meeting and Management.....	2-2
Task 1.0: Fleet and Demonstration Site Data Collection.....	2-2
Task 2.0: On-Board Truck Systems Design Integration.....	2-4
Task 3.0: Sleeper Cab Truck Retrofit .....	2-6
Task 4.0: TEP Preliminary Design .....	2-7
Task 5.0: Final Phase I Report.....	2-9
PHASE II TASKS.....	2-10
Task 6.0: Finalize Site Specific Design & Arrangements .....	2-10
Task 7.0: Shore Power Retrofits .....	2-11
Task 8.0: Install/Startup of Shore power TSE .....	2-11
Task 9.0: Monitor TSE Operation and Fleet Usage.....	2-13
Task 10.0: Marketing & Outreach .....	2-18
Section 3 - PROJECT BENEFITS.....	3-1
ENERGY BENEFITS.....	3-1
ENVIRONMENTAL BENEFITS: EMISSION REDUCTIONS.....	3-1
ECONOMIC BENEFITS.....	3-2
Section 4 - CONCLUSIONS .....	4-1
APPENDIX A - USER MANUAL .....	A-1
APPENDIX B - INSTALLATION MANUAL .....	B-1
APPENDIX C - WILTON EMPLOYEE FACT SHEET .....	C-1
APPENDIX D - IDLE REDUCTION TECHNOLOGY COST COMPARISON.....	D-1
APPENDIX E – ANL IDLING POSTER.....	E-1

## SUMMARY

Diesel heavy truck anti-idling laws exist in New York State but are not rigorously enforced. This is due to a lack of a widely accepted alternative to idling that provides power for heating, air conditioning, and other electrical appliances and convenience accessories for sleeper cab equipped diesel trucks. Idling during Federally mandated rest periods costs truck fleets and owner-operators not only through additional diesel fuel consumption, but also through additional engine maintenance and component wear costs associated with idling the engine. Moreover, the low-frequency vibration induced by engine idling impacts the driver's quality of rest. Although many drivers become accustomed to the noise and vibrations, the idling of truck tractor engines also results in localized engine emissions and noise pollution, and is exacerbated in high-density truck parking locations along Interstate Highway systems. Wide spread adoption of a cost effective idle reduction technologies will also reduce New York State's and our Nation's dependence on foreign petroleum imports.

There has been considerable progress made to develop alternatives to idling long-haul diesel trucks equipped with sleeper cabs. One alternative is Truck Electrified Parking (TEP) using either an "on-board" (or shore power) approach or an "off-board" (IdleAire - full services) approach. Shore power technologies provide grid-based electricity to the truck sleeper cab similar to the electrical hookups seen at marinas and recreational vehicle (RV) parks. In order to provide the necessary heating, ventilating and air conditioning (HVAC) to the truck sleeper cab, an electric powered air conditioning and heating unit must be installed "on-board" each truck tractor sleeper cab. The "off-"and "on-board" generally refers to the location of the HVAC and other electrical components used to provide the driver with cab comfort. The off-board approach supplies 120-volt alternating current (VAC) electric power as well as HVAC from a stationary overhead distribution system; no additional truck hardware or modifications are required other than the purchase of a window template which allows the service console to be temporarily installed in the passenger truck window opening. Off-board systems have been estimated to cost 3 to 6 times more than shore power systems with similar 120-VAC power hookup capability. New York State demonstrated the off-board IdleAire system on the New York State Thruway (NYST) at two rest areas near Syracuse and at the Hunts Point Meat Market in the Bronx. However, the Federal 21<sup>st</sup> Century Truck Partnership (21CTP) and the U.S. Department of Energy (USDOE) Essential Power Systems Program under the Office of Heavy Vehicle Technologies (OHVT) are focusing on the "more electric truck." The "more electric truck" will electrify on-board systems, including cab HVAC. As this transition of on-board systems occurs, much of the benefit of the off-board system will be diminished; therefore, shore power systems are a much more cost-effective idle-reduction solution. Most heavy-duty truck Original Equipment Manufacturers (OEMs) already offer shore power as standard or optional equipment on their sleeper cabs.

In order to explore the economics and operational benefits of shore power in New York State this project, which was managed by the Antares Group Incorporated with assistance from Shurepower, made use of a Dometic-Tundra electrically-driven HVAC unit sized for long-haul truck sleeper cabs; an Intellitec Smart Energy Management System; and a Xantrex truck inverter battery charging system with shore power compatibility, installed by Northway Transport Refrigeration (NTR) located in Albany, New York. The inverter charger system powers the on-board 12-volt direct current (VDC) hotel loads, communication equipment, and recharges the batteries when connected to the shore power system. Additionally, an 18-unit shore power facility was constructed at the Wilton Travel Plaza in Wilton in New York State. The demonstration focused on a fleet using the Northway (I-87) in New York State to move freight between Canada and the U.S.

The resulting project benefited the State of New York by demonstrating reduced diesel engine idling and associated noise, emissions, and diesel fuel consumption; and demonstrated a model TSE shore power system that could be replicated at a reasonable cost throughout the State.

## Section 1 - INTRODUCTION

Nearly every item in our homes, offices, schools and stores is delivered by heavy-duty trucks at some point. Heavy-duty trucks have taken on an even greater role in moving high value and time critical “just in time” freight over the last 10 years as the railroads have continued to maintain their historic role at moving bulk materials. Class 8 sleeper-cab tractor-trailer combinations are a common sight on New York highways and Interstates. These sleeper-cabs can be considered a mobile hotel room to the vehicle operator; they must be heated and cooled to maintain driver comfort sufficient to allow a restful sleep during Federally-mandated U.S. Department of Transportation (USDOT) rest periods. Normally this is accomplished by idling the main diesel propulsion engine of the tractor. U.S. Department of Energy (USDOE) studies have shown that the average sleeper cab tractor uses about 0.8 to 1.0 gallon of diesel fuel per hour of idling. In addition, engine idling impacts engine maintenance and component wear, which is estimated to cost between \$0.10 and \$1.00 per hour, depending on the calculation assumptions. The total estimated cost associated with idling for one hour with average diesel fuel costs at \$2.50/gallon<sup>1</sup> is \$2.65 per hour<sup>2</sup>. This adds an element of cost to fleet operations that reduces profits and impacts the viability and financial stability of both the larger truck fleets as well as individual truck owner-operators.

In addition, the operator of an idling truck is exposed to the low frequency vibration that the idling engine introduces into the tractor chassis and sleeper cab. This vibration interferes with restful sleep for many drivers. Moreover, an idling truck produces exhaust emissions and noise that can become a problem when many trucks are concentrated in a rest area or truck stop. The emissions may also have an impact on the driver’s health and alertness during an extended rest period, which could potentially impact traffic safety.

Twenty states (including New York) and the District of Columbia have truck and bus anti-idling laws.<sup>3</sup> However, the anti-idling laws in most states are not well enforced, as low and high ambient temperatures demand some level of cab comfort to be provided to resting drivers. Until just recently, there have been no real cost-effective alternatives to diesel engine idling during federally mandated truck operator rest periods. In the past several years there has been interest in developing shore power systems for the trucking industry, which is derived from the dock-side systems used at marinas to supply 120-VAC electricity, telephone, water and communication services to docked boats. Similar systems are also used at recreational vehicle (RV) parks and campgrounds. Currently, approximately 10% of long haul Class 8 sleeper cab truck tractors have the capability to directly hook up to these systems, but most trucks do not have 120-VAC heating and cooling or auxiliary equipment. However, nearly all long haul Class 8 sleeper cab tractor manufacturers in the U.S. now offer some form of shore power capability, either as standard

---

<sup>1</sup> According to USDOE website [eia.doe.gov](http://eia.doe.gov) as of August 2005

<sup>2</sup> Based on costs calculated according to TMC’s Recommended Practice 1108

<sup>3</sup> American Transportation Research Institute “Compendium of Idling Regulations,” August 2005



equipment or an option. Enabling long haul Class 8 trucks to use shore power requires the installation of an inlet (exterior supply connection), wiring, several internal convenience outlets, and the use of an extension cord to connect to a grid-based power source. These systems can typically include telephone, cable TV, and Internet connections. The simplest form of shore power would only require the use of a power source and a heavy-duty extension cord, which could be run into the cab and plugged into a portable heater or any other appliance desired by the driver.

There are currently two forms of Truck Electrified Parking (TEP) that use either an “on-board” (shore power) approach or the “off-board” (IdleAire - full services) approach. Shore power technologies provide grid-supplied electricity to the truck sleeper cab similar to the electrical pedestals seen at marinas and RV parks. In order to provide the necessary heating, ventilating and air conditioning (HVAC) to the truck sleeper cab, an electric powered air conditioning and heating unit must be installed “on-board” each truck sleeper cab. The “off-“and “on-board” generally refers to the location of the HVAC and other electrical components used to provide the driver with cab comfort. The off-board approach supplies 120-VAC electric power as well as HVAC from a stationary overhead distribution system; no additional truck hardware or modifications are required other than the purchase of a window template which allows the service console to be temporarily installed in the passenger truck window opening.

Although the number of shore power capable tractor trailers is increasing rapidly, IdleAire Corporation has chosen to address this issue with a fully integrated off-board system. IdleAire supplies and operates a TEP system that delivers heating, cooling and electricity directly to the truck via a flexible duct from an overhead gantry system. The IdleAire approach requires no sleeper cab truck modifications other than the purchase of a \$10 window template. However, the cost of the IdleAire’s infrastructure has been estimated to be between three and six times more expensive than the shore power approach. NYSERDA and the New York State Thruway Authority (NYSTA) funded the first Interstate Highway installations of IdleAire at two NYSTA service plazas. A complete report on the operations, benefits, and costs associated with IdleAire’s facilities was funded by NYSERDA and completed in January 2005 by Antares. This report is available from NYSERDA and is currently posted on their web site at: <http://www.nyserda.org/publications/I-90TSEDemonstrationReportJan05.pdf>

One of the biggest market concerns with off-board TEP systems is the changing technological nature of the nation’s long haul truck fleet. The USDOE/USDOT/U.S. Department of Defense 21CTP, in partnership with the trucking industry, is setting the standards for a more energy efficient truck that uses electrical auxiliaries and subsystems including water pumps, oil pumps, cooling fans, air conditioning compressor and cab heating. This change will allow the direct connection of shore power for heating and cooling of the cab unit thus obviating the need for off-board heating and cooling unit. These changes could occur rapidly

depending upon several factors, which include diesel fuel costs, demand, and the health of truck tractor original equipment manufacturers (OEMs).

According to Xantrex Technology Corporation, shore power and related equipment options have grown in numbers by 50% annually over the past several years. An online survey conducted by Xantrex concluded that 90% of drivers would like to use shore power if it was widely available. Even without extensive infrastructure availability, it is estimated that approximately 10% of the nearly 500,000 long haul vehicles currently have shore power and related equipment. These numbers are expected to grow rapidly with the expansion of shore power infrastructure at travel plazas, truck stops, and rest areas. Fleets are already installing shore power receptacles at their own terminals and depots and can often utilize existing outdoor AC receptacles at terminals, shipping docks and warehouses. Although there are several different technologies that could be used successfully to reduce idling, shore power provides the lowest cost, simple and flexible solution to the end user. It also provides the greatest overall environmental benefits.

Additionally, Phillips and Temro, emerging as the leading manufacturer of on-board shore power wire distribution kits, sold approximately 25,000 kits to through 2004. Between 1998 and 2002 approximately 2,000 kits were sold per year, with sales increasing in 2003. 2004 saw a major jump to 10,000 units, or about 10% of sleeper fleet production. Growth is expected to double each year, with an expected penetration of 50% by 2009. By 2006, all major heavy-duty truck manufacturers will offer a shore power option, including: Freightliner, Volvo/Mack, International, and PACCAR. Further evidence of the shifting demand for shore power electrification is demonstrated by the fact that Caterpillar, a major manufacturer of diesel engines and equipment, has invested millions of dollars in the MorElectric truck. This heavy-duty truck system replaces many of the traditionally belt driven components, including the air conditioning compressor, with an electrically driven system. This allows the heating, ventilation and air conditioning (HVAC) system to be powered with either the alternator/generator or with shore power. PACCAR, Volvo and Freightliner have also shown interest in these types of systems.

The demonstration conducted and managed by Antares was designed to address the needs for (1) a low cost alternative to supplying heating and cooling and (2) electrical and communication capabilities for long-haul sleeper-cab drivers. The approach makes use of available electric technologies for cab cooling and heating as well as marina and RV electrical power technologies to demonstrate a shore power system for the current (legacy fleet) trucks with block heaters and cab shore power connections; and that is fully compatible with the new (and future) “more electric truck” technologies that will be introduced over the next two to five years. Nearly every shore power capable truck (the legacy fleet) today uses 120-VAC power connections except for a handful of Caterpillar powered trucks developed and demonstrated with funding from the US Government and NYSERDA. These trucks were designed to use 120/240-VAC power and have successfully used 120/208-VAC supplies as well.

The life expectancy of the shore power electrical distribution hardware is longer than the life expectancy of sleeper cab truck systems. Therefore, the truck based systems are likely to see more technological advances in a shorter period of time as we expect to see a continuous upgrade in on-board systems to accommodate the needs and desires of long-haul truck drivers. The stationary infrastructure should be designed to accommodate the future needs of the sleeper cab, or should be readily adaptable to future requirements. The overall goal of the project was to demonstrate the benefits of shore power TEP as an idle-reduction alternative.

## **Section 2 - PROJECT EXECUTION**

### **PROJECT OVERVIEW**

Antares researched, designed and managed the installation of a sleeper cab shore power system that includes a Xantrex inverter/battery charger, Phillips and Temro load center and wiring, 120-VAC interior breaker panel, Intellitec Smart Energy Management System, Dometic Tundra HVAC system, and exterior shore power and communication connections. A number of different components were researched and evaluated, but the above components were determined to best serve the driver. The location of the companies and businesses was considered in selecting components, with the highest priority given to companies in New York State. To complete the retrofit and demonstrate on-board shore power equipment, a fleet was selected that regularly travels along the I-87 Northway.

In addition to demonstrating the on-board equipment, stationary shore power infrastructure was also constructed and demonstrated at the Wilton Travel Plaza, north of Albany along I-87. A total of 18 shore power pedestals were installed along with a payment and control system that monitors and controls utilization. Antares was contracted to monitor the system for a minimum of one year, which was accomplished from August 2004 through August 2005, 13 months of operations.

### **SCOPE OF WORK**

The project was divided into two distinct phases. Phase I provided sufficient information on the potential fleet use of shore power infrastructure and HVAC equipped sleeper cab trucks as well as the cost of sleeper cab conversions and a standard shore power installation. NYSERDA made a decision to move forward with Phase II, based on this project-specific information. Phase II built on Phase I and provided a real world field test of the shore power infrastructure and truck integrated HVAC system at an existing truck parking area on the I-87 Northway (Wilton Travel Plaza). The Phase II documented results will allow NYSERDA, NYSDOT, New York State Department of Environmental Conservation and other US organizations to make a true comparison between the shore power and off-board TEP systems before widespread State agency support is implemented.

The objectives of Phase I included: TEP demonstration site selection; participating truck fleet selection; on-board truck system (HVAC, inverter/charger, shore power connection and safety components) integration design and physical installation on a single tractor; TEP system site specific design; and documentation of the Phase I effort.

The objectives of Phase II included the detailed design, installation, and monitoring of the Shurepower facility for a minimum of 12 months of operation; retrofit of additional trucks (if funding is available);

shore power system data collection including: energy use, petroleum savings, emissions benefits, driver (end-user) feedback, and system reliability data; business/financial model development; outreach and outreach documentation; and the completion of this final report.

## **PHASE I TASKS**

### **Task 0.0: Kick-Off Meeting and Management**

The Project Team initially met with NYSERDA staff on September 12, 2002 to discuss the Phase I effort in detail and obtain comments and suggestions relative to the execution of the Phase I task plan. This meeting also allowed for direct discussion between the Project Team, NYSERDA staff and NYSDOT staff regarding the criteria for selecting the demonstration site as well as for the selection of a participating fleet.

Progress reports were also submitted to NYSERDA on a monthly basis throughout the project until project activities were reduced. During Phase II site operations monitoring, activities were mainly composed of monitoring and operating the Wilton Travel Plaza facility; therefore, only quarterly progress reports were required.

### **Task 1.0: Fleet and Demonstration Site Data Collection**

The goal of Task 1 was to locate a fleet and host-site willing to participate in the shore power TSE demonstration. Eighty fleets were contacted to determine their level of interest in participating in the program. Many fleets were interested, but some were concerned about putting the vehicle out of service while the shore power equipment was to be installed. Others were simply not interested in saving fuel or were concerned about system reliability. Several fleets indicated they were evaluating other idle-reduction technologies. Most contacts with the fleets were made in the first quarter 2003. During this period, diesel fuel prices were near \$1.50 per gallon, so the incentive to invest in idle-reduction technologies was not as great as today. Generally, the willingness to participate was not as strong as it would be today, with fuel cost nearly double of what they were at the time. **Figure 1** below shows the average fuel prices in the use and Mid-Atlantic States since July 2003. Although the project was conducted in New York, regional fuel prices effected the decision to utilize idle reduction technologies.

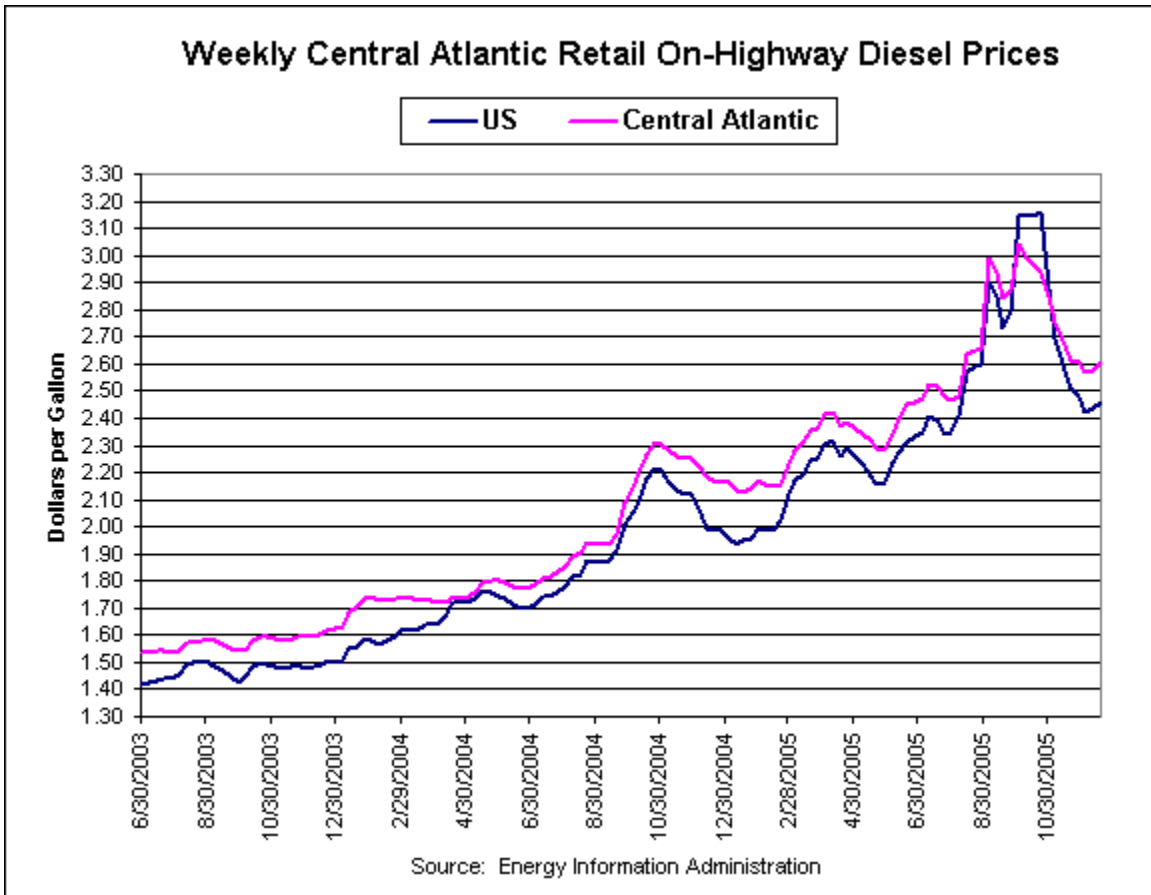

**Figure 1**

A survey of truck stops and rest areas was conducted along I-87 to determine the size and occupancy levels of truck parking areas along I-87. Site evaluation criteria included access from the north and southbound directions of I-87, facility amenities, number of truck parking spaces, parking lot configuration and the receptiveness of the host site owner to agree to participate in the project. The following I-87 rest areas and truck stops were evaluated for the shore power facility:

- Clifton Park (Northbound),
- Glens Falls (Northbound),
- Point Au Roche (Northbound),
- Valcour (Northbound),
- High Peaks North (Northbound),
- High Peaks South (Southbound),
- Beekmantown (Southbound), and
- Glens Falls (Southbound).
- Wilton Travel Plaza (Exit 16 – accessible from both directions)
- Riverside Gas & Oil (Exit 17 – accessible from both directions)

Initially, site selection was focused on state owned rest areas; however, approvals were difficult to solidify. As it turned out, one of the highly scored rest areas had recently been constructed and therefore the state DOT was against cutting or disturbing the pavement in any way. This and the fact that some of the rest areas were located in the Adirondack State Park, required another level of concerns and approvals. At the time, there were also federal and state prohibitions on commercialization of rest areas. No commercial activities were allowed at rest areas other than “vending” machines, including TEP. As a result, NYSDOT petitioned for clarification of the “vending issue” and set the stage for the prohibition to be overturned, which as subsequently adopted in the recently signed 2005 Transportation Bill.

Due to the above issues, site selection was refocused to a privately owned truck stop. Based on the survey data, the best equipped facility was the Wilton Travel Plaza. With over 150 parking spaces, it is the largest truck parking facility surveyed in New York and has the most comprehensive list of truck driver amenities including a restaurant, restrooms, showers, truck service, diesel fuel island, convenience store, offices and large paved parking lot. This facility proved to be to be an ideal location for a shore power TEP demonstration facility.

While evaluating potential host-sites, a list of company trucks was composed and tabulated to determine which fleets had the most significant numbers of trucks traveling along I-87. A large number of trucks were base plated in Canada, which was expected since I-87 leads to the Canadian boarder. Fleet selection evaluation criteria included the number of truck sightings, location of the truck company’s headquarters and terminals, average age of fleet sleeper cab tractors; planned truck purchases (to coincide with the fleet conversions planned for Phase II), number of trips along I-87 each month, willingness to participate and reduce idling, and corporate level of dedication to environmental concerns and programs such as EPA’s Smartway. After several months of research and surveying fleets, it was determined that KLLM of Jackson, Missouri would be the best fleet for the conversion. KLLM has over 2,000 long-haul trucks in the United States and assured the Contractor that they could take a newer vehicle out of service for the required conversion period.

### **Task 2.0: On-Board Truck Systems Design Integration**

Under this task, Antares finalized the in-kind commitments for the on-board truck electric systems including the following components:

- 10,000 BTU Dometic Tundra in-cab electric HVAC system with remote control
- Xantrex Inverter Charger with remote display
- Phillips and Temro Cab Power wiring distribution kit
- Intellitec Smart Energy Management system

Additionally, the following components were added to enhance the capabilities and experience using the shore power system:

- Television with integrated DVD player
- 120-VAC refrigerator
- Microwave oven
- Coffee maker

Initially, Antares expected to use a HVAC system manufactured by Carrier, but due to the down sizing of the Carrier facility in Syracuse, New York, and the lack of a heavy-duty unit manufactured specifically for long-haul trucks with adequate capacity to heat and cool a large sleeper cab, Dometic was contacted for support. The Dometic Tundra HVAC unit automatically maintains a preset temperature by cooling or heating the cab when connected to shore power. A remote is included with the system that allows the driver to adjust the temperature and fan speed.

The Xantrex inverter charger can both invert energy from the 12-VDC battery system into 120-VAC, or it charge the 12-VDC batteries when connected to (120-VAC) shore power. This allows the driver to use battery power (without shore power) for short periods of time to power the refrigerator, coffee maker, microwave or other appliances. Battery power could be extended by installing several additional batteries, but would increase the cost and weight of the system. The charger maintains the battery energy to ensure reliable starting power when connected to shore power.

The Phillips and Temro wiring kit includes a load center with ground fault and breaker protection, “plug-and-play” wiring, convenience outlets for the interior of the cab, and an external weather proof inlet. With an extension cord extended from the inlet to the shore power pedestal, 120-VAC power is brought into the cab and distributed to several outlets in a similar fashion to our homes.

To complete the retrofit, Albany, New York based installation facilities were contacted to determine if they had the equipment and knowledge to handle the installation of the shore power related equipment. Northway Transport Refrigeration (NTR) showed the willingness and capabilities to help the project team complete the installation design and retrofit. Additionally, NTR is located within close proximity to I-87 and Wilton in the event any problems are encountered with the installation or long-term reliability of the system. NTR specializes in trailer refrigeration unit (TRU) repairs and service. They have 24-hour emergency repair services available to drivers who encounter “break-downs” in the field. For more extensive repairs, NTR has a fully outfitted multi-bay repair facility in Albany, New York (**Figure 2**).





**Figure 2. NTR Installation Facility in Albany, New York**



**Figure 3. Cab Retrofit Appliances**

### **Task 3.0: Sleeper Cab Truck Retrofit**

A 2002 year model Freightliner Century Class long-haul tractor was supplied to NTR by KLLM on June 18, 2003, to complete the retrofit. During the scheduled installation period, a relatively high number of emergency TRU repairs were brought into the shop due to high temperatures in the 90s. The increased loads required to maintain acceptable temperature within the trailers lead to higher than average breakdown rates. Many of these trailers carry temperature sensitive loads that could cost thousands of dollars to replace if temperatures were allowed to increase excessively. Therefore, these emergency repairs had priority and the shore power retrofit progressed slower than anticipated.

Antares worked closely with NTR to devise an installation procedure and plan. Once completed, NTR supplied Antares with a bill of materials, labor, and estimated costs for future retrofits. As with any custom component installation, the time required for the initial retrofit is far greater than subsequent installs. Much of the time required was used to review the product manuals and become familiar with the equipment. The entire installation took approximately 34 man hours. NTR estimated they could complete a similar installation without the additional appliances (TV, coffee maker, microwave, and refrigerator) in 8 to 10 hours in the future.

The initial retrofit was well documented; a User Manual was composed by the Contractor as displayed in **Appendix A**. Additionally, an Installation Manual was composed by Antares to aid installers with future retrofits. The Installation Manual is attached as **Appendix B**. **Table 1** shows the estimated labor required to install the referenced shore power related components and the potential time required once a technician familiar with the components and installation procedure. The block heater inlet was relocated to the drivers

side of the vehicle so all inlet connections were on one side of the vehicle. The TV and coffee maker were simple to install and only required a safety strap to ensure they would remain secure while driving.

**Table 1. Estimated Installation Time**

<b>Component</b>	<b>Hours</b>	<b>Potential Time</b>
Dometic HVAC	7.5	3.5
Xantrex Inverter	6.5	2.5
Phillips and Temro Wiring	4.0	1.5
Energy Management System	7.0	1.5
Dometic Microwave	2.0	0.5
Black & Decker Coffee Maker	1.0	0.25
TV DVD Combo	1.0	0.25
Internet Cable Receptacles	2.0	0.5
Relocate Block Heater	1.5	0.5
Testing	1.5	0.5
<b>Total</b>	<b>34.0</b>	<b>11.5</b>

Once completed, all systems were tested to ensure they were functioning correctly. The vehicle was also road tested to determine if any immediate problems would arise. By road testing the vehicle, it was determined that the turn-table plate in the microwave was rattling and therefore it was removed and stored in a cabinet. After the road test, all electrical system were retested and verified to be working.

**Task 4.0: TEP Preliminary Design**

Preliminary design criteria were formulated and the basic concept of the system was determined under this task. Conceptually, the idea is simple: provide truck drivers with uninterrupted electrical power for the HVAC, block heater, and other hotel loads. This concept has been demonstrated for many years in the RV and marina industries. The connection hardware (pedestals) can be easily adaptable from these industries.

Several pedestal manufactures were contacted to determine the best option for the system at the Wilton Travel Plaza. Although these companies had similar products, Marina Power of Williamsburg, Virginia appeared to have the best overall product for the price. Since no TEP electrical standards exist for the trucking industry, RV standards were used. To accommodate a wide range of users and power requirements, Antares opted to offer three levels of power: 120-VAC 20amp, 120-VAC 30amp, and 120/208-VAC 50amp. Each pedestal has three receptacles consistent with RV standards.

Generally, marinas and RV parks with shore power have an attendant on-site to collect “rental fees” at each location. In order to control utilization and simplify access to the shore power pedestals, it was decided

that an automated payment and control system would be developed. Since no vendors of such technology existed, Antares began to contact payment kiosk companies that could potentially aid in the development of the payment/control system. Fuel system payment machines seemed to be a logical starting point; the functional concept is similar. However, one controls the flow of fuel whereas the new system would control access to electrical energy, or shore power. Eventually, Antares located a fuel system kiosk provider willing to develop the new system. Infonet Technologies of Vancouver, British Columbia agreed to develop the system for a fixed price. Antares also contemplated developing the system on their own, but it was decided that a company with experience in this area could develop the system more efficiently.

Antares specified a system that could accept payment with either credit cards or prepaid cards. The system would also have the capability to record each user's personal data, payment type, hours used, and energy consumed. **Figure 4** shows a conceptual graphic of how the system would be laid out. All hardware would have a life expectancy of at least 10 years and function reliably in all weather conditions encountered in North America. With the hardware specified and selected, Antares was able to move on to the site specific design and construction.

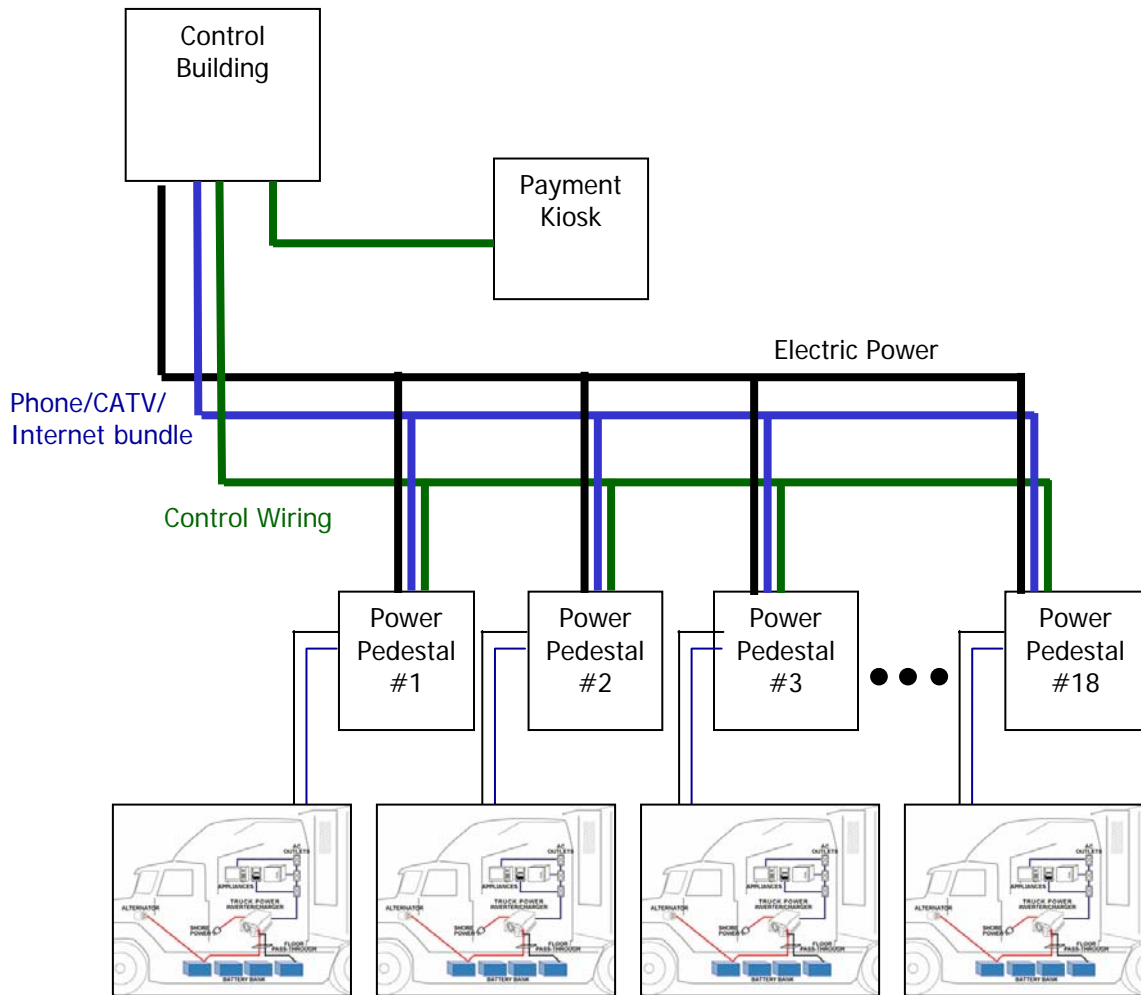

**Figure 4. Shurepower System Layout**

**Task 5.0: Final Phase I Report**

A report was prepared detailing the Phase I effort and task outputs, which is available from NYSERDA. The report included discussions of the financial and business viability of shore power and the demonstration shore power installation. The shore power system was also compared to other idle-reduction technologies and the benefits of shore power were quantified. Also, a detailed schedule of the Phase II implementation was provided along with a Phase II work-plan and budget. A detailed listing of demonstration in-kind partners and their level of project participation was also provided. This information assisted NYSERDA in the go/no-go decision for Phase II of this demonstration. Based on the Phase I Report and discussions with Antares, NYSERDA decided to proceed with Phase II.

## **PHASE II TASKS**

The Phase II effort was initiated after NYSERDA authorized the contractor to proceed. The following section describes the tasks completed under the contract.

### **Task 6.0: Finalize Site Specific Design & Arrangements**

With the host-site and hardware selected, Antares was able to prepare for the installation of the shore power equipment. Together with NYSERDA, Antares decided that the connection hardware (pedestals) could be installed at the back perimeter (southern end) of the parking area. This area is quietest area of the parking lot and is adjacent to trees and grass making it an ideal area to be designated as an “idle free green zone.” At the time, this area was an unpaved trailer drop area. Frank Parillo, owner of the Wilton Travel Plaza, agreed to pave this area to accommodate the new hardware. Antares agreed to use project funds to pay for the portion required for the side walk and shore power pedestals.

Once a suitable area was designated for the new shore power facility, a local engineer was subcontracted to complete the plans for construction. In most cases, an attempt was made to use off-the-shelf hardware and components to reduce costs and simplify the installation. Antares staff discussed other issues such as impact protection, transformer capacity, voltage drop, snow removal and kiosk location to ensure the best possible design for long term operations.

Bid letters and plans were sent to several regional contractors to competitively bid on the construction and electrical work. Although most of the work was fairly straight forward, the bids ranged widely, with the highest bid being nearly double of the lowest bid. Antares selected a local contractor to complete the construction and installation, which took approximately 3 weeks including the delays described below.

Initially, Antares contemplated installing a barrier design between every other parking space as shown in **Figure 5** below. However, this design requires additional space and is more likely to be hit by trucks than if the pedestals were mounted on the perimeter of the parking area. With the pedestals off to the side, drivers are also less likely to be hit by trucks pulling into the parking spaces. The barrier design would also require extension cords to be passed under the vehicle if the inlet is not located on the correct side, thus creating an additional tripping hazard. With the connections at the front of the vehicles, drivers can walk between trucks without the risk of tripping over the cords. At the perimeter of the lot, the cords extending to each pedestal are easily visible with lights mounted in each pedestal. All factors considered, it was decided that a single pedestal would be placed in front of each of 18 parking spaces as shown in the **Figure 6** below. Original plans called for 20 shore power parking spaces; however, the site owner had plans to lease some of the land to another party and therefore only 18 spaces could be electrified.

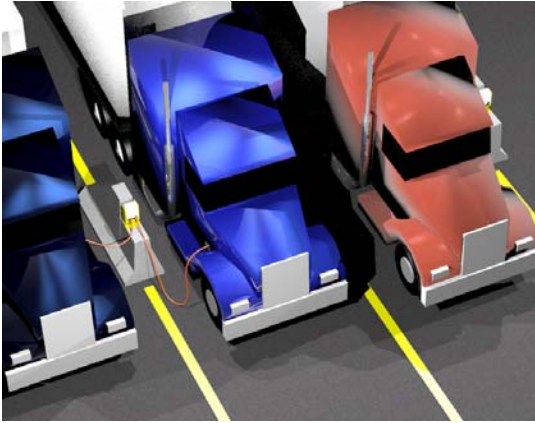

**Figure 5. Truck Barrier Design**



**Figure 6. Newly Installed Shorepower Facility at the Wilton Travel Plaza**

### **Task 7.0: Shore Power Retrofits**

During the course of the installation, the project team became aware of a reasonable number of already shore power capable trucks on site. Rather than immediately retrofitting trucks from a fleet, identification of a “synthetic (syn) fleet” of shore power capable trucks was pursued. Antares originally planned to retrofit up to 20 vehicles with shore power equipment; however, due to the “syn fleet” identification and study, budgetary constraints prohibited further retrofits.

Most long-haul tractor manufacturers currently offer some type of shore power option on new vehicles. In fact, Volvo supplies their higher end tractors with shore power wiring as standard equipment. Phillips and Temro sold over 37,000 cab power kits through 2005. Another company with a similar name, Phillips, also sold a significant number of kits to the long-haul market, primarily to Freightliner. Total production is currently estimated to about 10%. Combined production numbers are expected to increase in the future as all major long-haul truck manufacturers will offer shore power as an option in 2006.

### **Task 8.0: Install/Startup of Shore power TEP**

Once the plans were finalized and stamped by the New York Professional Engineer, they were submitted to the Town of Wilton for approval. The town board meets monthly to review project submittals and generally approves them the at the following month’s board meeting. Therefore, this process took over two months to complete. Once the project permits were granted Antares subcontractors began work to complete the facility in time for the National Idling Reduction Conference held on May 17 through 19, 2004 in Albany, New York. On the last day of the event, attendees traveled 30 minutes north on I-87 to the Wilton Travel Plaza for the Grand Opening and Dedication Ceremony.

Prior to construction, the land was surveyed to determine the precise locations of the foundations and pedestals. Stakes were placed at all critical points prior to construction. Construction activities were fairly straight forward and required only about one week, excluding the prefabricated utility building and electrical work. Initially, the building ordered was too low to clear the switchgear for distributing the electricity to the pedestals, due to a misunderstanding by the New York Professional Engineer who completed the drawings. Coordination and scheduling of the utilities also slowed the process, but the contractor was able to manage the construction process and help make the final electrical and control system wiring connections.

The initial price for the control system was approved by Antares, but was slightly more than anticipated. However, InfoNet seemed willing and capable of completing the work by the agreed date for a fully functional system. As the project progressed additional costs were incurred, but at that point it would not have made sense to abandon the work completed to that point, so Antares agreed to forge on to the completed product.

Using the system requires drivers to sign up in the convenience store to receive a user card. The shore power system includes a payment, control and monitoring system that allows users to swipe the magnetically encoded user card to activate the system. Once the card is swiped the user is prompted to enter the parking space number he/she wishes to use. Activation of each pedestal allows the drivers to use power, Internet, phone and cable television connections until the service is deactivated.



**Figure 7. Pedestal and Utility Building**



**Figure 8. Grand Opening Event - May 19, 2004**

The Shurepower Truck Electrified Parking (STEP) facility officially opened and was dedicated by members from NYSERDA, Niagara Mohawk Power Company, DOE, Antares and NYSDOT on May 19, 2004. Antares and Shurepower staff demonstrated the system by connecting the CAT MorElectric truck and KLLM retrofit truck to the shore power system as displayed on the cover of this report. Reporters were

on hand to observe the system functioning and ask the Sponsors, Contractor, and Subcontractors specific questions. Both the system and the trucks operated flawlessly.

### **Task 9.0: Monitor STEP Operation and Fleet Usage**

The STEP control system records all utilization of the system with a Pentium based workstation. This data is stored locally and uploaded periodically to Antares' server. This redundant system minimizes the possibility of losing all historical data. The system is also capable of notifying the system administrator of any failures or requirements for routine maintenance such as when the receipt roll runs low.

The Project Team also monitored the use of the shore power system installed in the KLLM truck for one year. The driver was asked to complete weekly survey forms to notify Antares of any faults or difficulties encountered in using the system. Overall, the driver was very happy with the system, stating he wished there were more locations with shore power infrastructure. The system was primarily used at home and at company terminals. Unfortunately, the driver lived only a couple of hours from Wilton; therefore, he only used the facility at the Wilton Travel Plaza a few times. However, the driver was able to attend the National Idle Reduction conference and show the truck connected to the system at Wilton. During the last week of the demonstration period, Jerry Laymon wrote project managers a note stating he had no problems with the system and, "It's been nice working with all of you. I really enjoyed everything you put in that truck. Thank you, Jerry."

Based on data recorded by the control system, utilization (pedestal connection time) was highest in the winter when temperatures dropped and requirement for heating increased as shown in **Figure 9** below. Energy use also increased when pedestal connection time was highest as shown in **Figure 10**. There was also a direct correlation of energy use to temperature; when temperatures were low, energy demand was highest (**Figure 11**). Based on this data, temperature was the single greatest influence on utilization. Using shore power to heat the cab is simple and inexpensive. Small portable heaters can be purchased at many locations for under \$25 and Shurepower offers its Level 1 kit for \$189 that includes a portable heater with a fan and safety shut-off switch (in the event of overheating or if the driver was to drop a blanket over the heater). Air conditioning is typically more expensive; dedicated electric HVAC systems designed for trucks start at around \$1500. However, some drivers have chosen to use small portable window air conditioning units that start at approximately \$100.

Several other factors could have influenced utilization including: marketing efforts, fuel prices, and the number of shore power capable long-haul trucks. The Wilton employee marketing incentive offered from December 2004 through February 2005 appears to have increased utilization significantly (see next section on Marketing and Outreach for details on the employee incentive program).



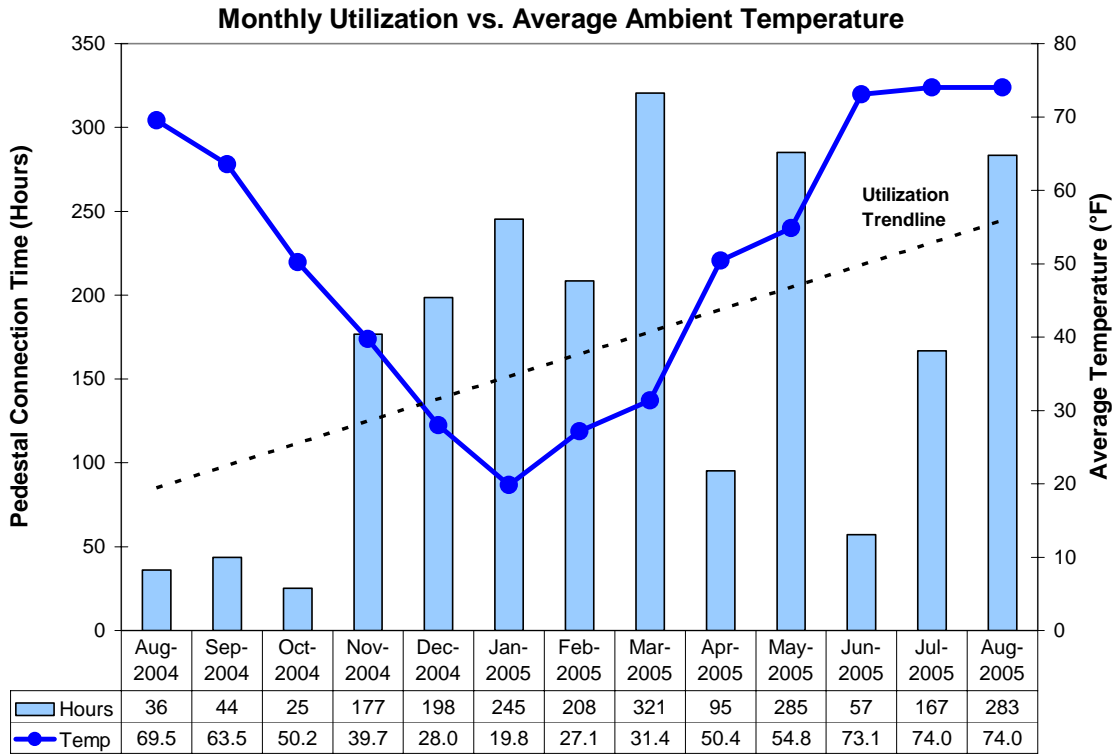

**Figure 9**

In general, utilization of the Shurepower system increased with time as more drivers became aware of the available services and benefits. This is shown by the linear trendline in **Figure 9**. Project partners have come to the conclusion that utilization would have been higher if someone was stationed on-site to explain how the system works, encouraged utilization and informed drivers of the many benefits of using the system, including saving money. Shurepower is considering this type of marketing effort in the future; although, they will probably wait until other sites are constructed and operational. This will allow the hiring a single person to handle all sites in the region.

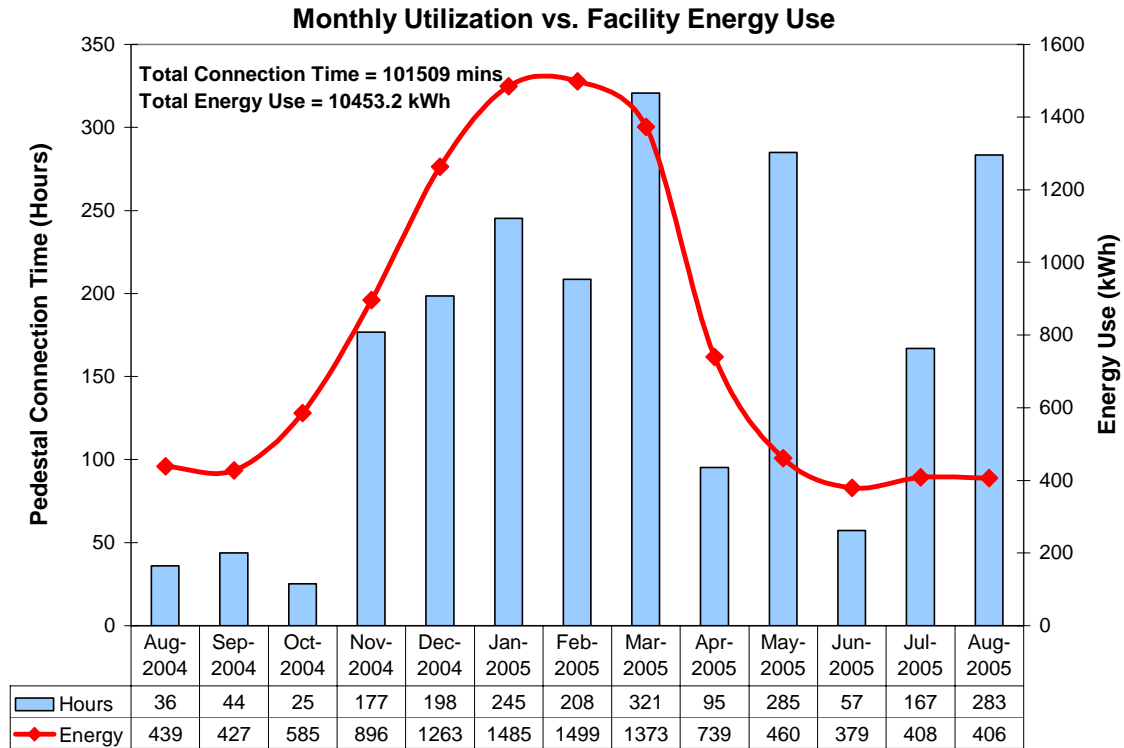

**Figure 10**

Drivers typically need power for heating in the winter and cooling in the summer, depending on the climate. Drivers also use energy to power televisions, DVD players, microwave ovens, refrigerators, laptops, and other appliances. The highest cab load is generally the HVAC system which can consume 1000 to 2000 watts. Cab heating combined with block heaters and fuel warming devices creates the heaviest load during the colder months. Based on **Figure 10**, energy use was highest in the winter, which is a result of both high utilization and high energy demand. This combined effect required more than three times the energy demand in the winter versus the more mild seasons.

Although, temperatures in the Albany, New York region are high enough to require air conditioning in the summer, five factors contributed to lower energy demand in the warmer months: temperatures vary from the human comfort zone to a greater degree in the winter than in the summer, there are relatively fewer numbers of sleeper cabs with electric air conditioning versus electric heating, air conditioning generally requires less energy than heating (especially when “heating” includes block heaters), drivers predominantly take their rest periods at night when temperature and humidity are lower (therefore, the requirement for cooling is lower), and the absence of an employee incentive program. Although the employee incentive program is not seasonally related it did help increase utilization in during this period. As more drivers adopt fully functional electric HVAC systems or those like the Caterpillar has developed, summer demand

will increase. Once this occurs, the Spring and Fall (milder temperatures) periods are anticipated to require the lowest overall energy consumption.

Energy use by the facility was derived from energy bills provided by Niagara Mohawk Power Company (now National Grid). The energy recorded and billed is based on energy used by the entire shore power system including loads from the pedestals (users), lights, computer, payment kiosk, control system and HVAC for the utility building. The non-user (overhead) load is estimated to average 774 watts. If this value is subtracted from the overall value, each sleeper cab averaged 1.46 kilowatts of draw from the system. This corresponds well to the preliminary estimates of anticipated energy use by each truck sleeper cab of 1.5 kilowatts. Antares requested to have energy use for each pedestal recorded, but control system provider could not include this functionality within budget.

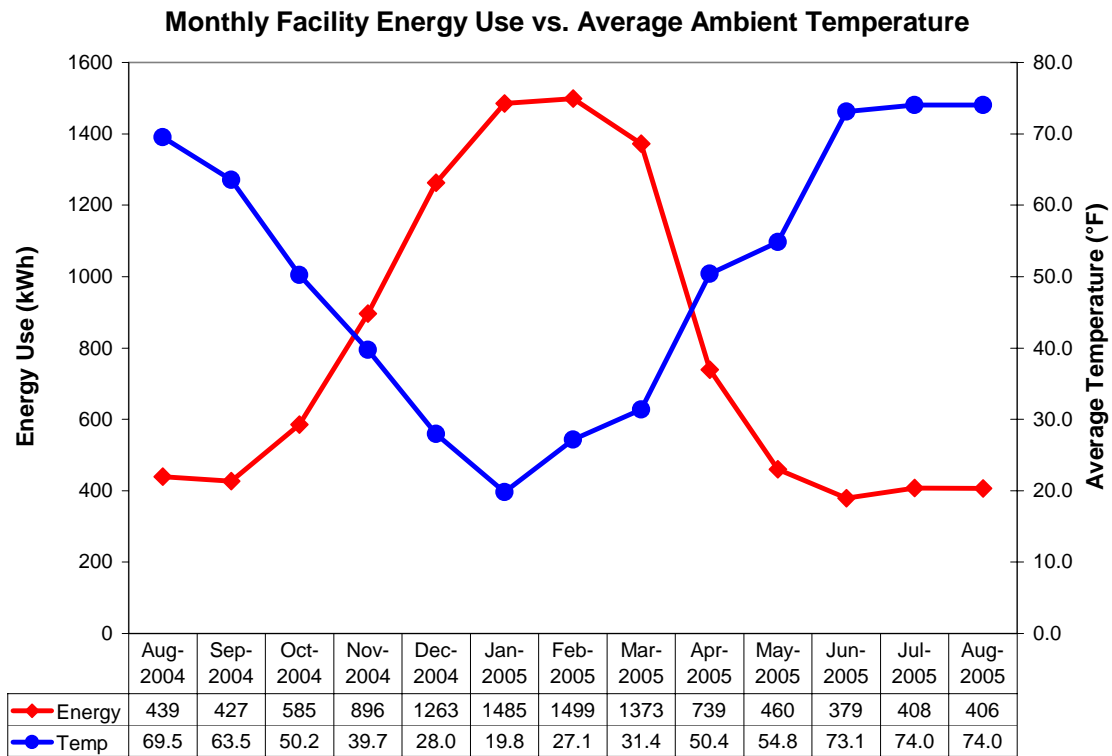

**Figure 11**

Diesel fuel prices could have also positively effected utilization; however, it is not clear how dramatic this effect was. Although, diesel fuel prices in the Mid-Atlantic states increased fairly consistently over the reporting period, utilization was more consistent with other factors mentioned above. Diesel fuel prices undoubtedly helped utilization, but there is no direct evidence to support this trend. The trendlines in **Figure 12** show that utilization grew more rapidly than diesel fuel prices; therefore, it is unlikely that diesel

fuel prices were solely responsible for the increased utilization. The marketing effort and simple fact that more drivers became informed about the many benefits of the system had a more pronounced effect.

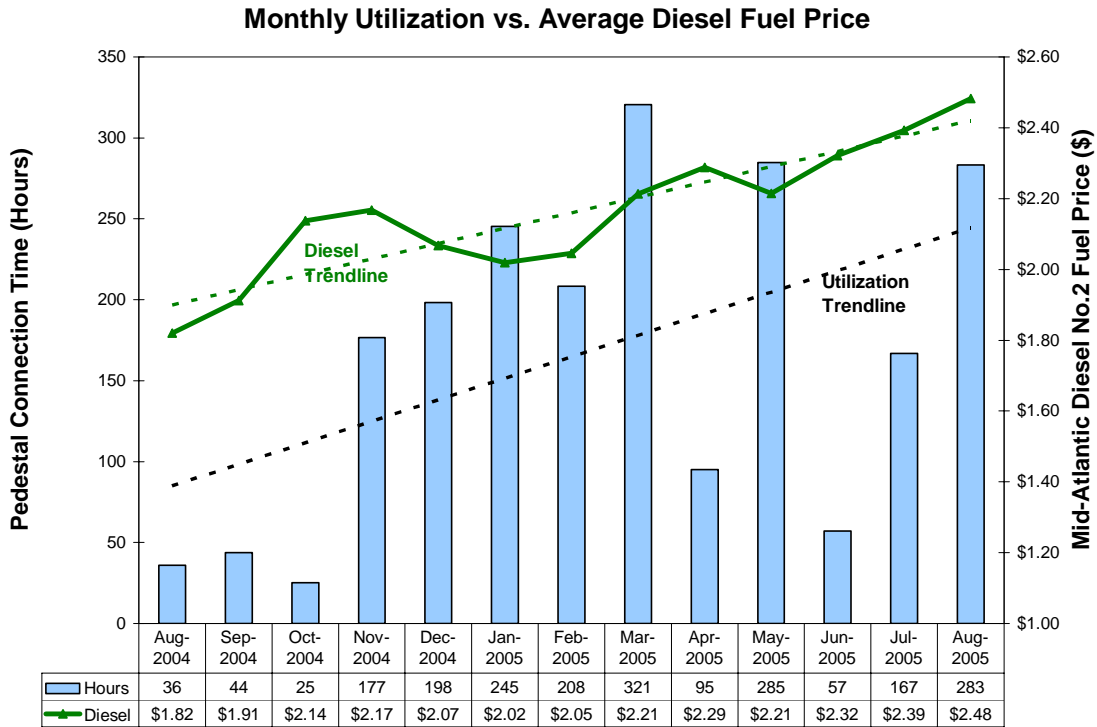

**Figure 12**

Considering the following factors: only 10% of sleeper cabs are currently readily capable of using shore power, direct marketing to drivers was minimal, and the fact that the Wilton Shurepower facility is the only known shore power site on the East Coast, utilization was near the expected levels. As more shore power facilities become available, the incentive to adopt and use such systems will be greater. An increase in future diesel fuel prices and legislation prohibiting engine idling will also help push the market to adopt idle reduction technologies and invest in shore power infrastructure. New ultra low sulfur diesel (ULSD) fuel regulations effective in 2006 will further increase the cost of on-road diesel fuel. This “new” fuel combined with the more stringent 2007 EPA truck emission standards, will likely reduce fuel efficiency slightly due to additional emission devices. These regulations require very low sulfur content levels to be compatible with the future emission reduction technologies.

Overall, a total of 207 transactions were recorded that represent 2,142 hours of use over 13 months. The average duration per visit was approximately 10.3 hours which corresponds to the 10 hour mandated rest period. A total of 10,361 kilowatt hours were consumed, including overhead items such as lights and equipment in the utility building.

### **Task 10.0: Marketing & Outreach**

A significant amount of marketing was conducted to reach the target market. Although shore power could be used by simply running any heavy-duty extension cord into the truck cab, most drivers resist change without a fleet or significant monetary incentive to adopt an alternative. Additionally, most fleet drivers do not pay for fuel out-of-pocket so there little incentive for the drivers to invest in idle-reduction technologies. However, a growing number of fleets are offering idling programs that incentivize reduced idling time. Therefore, greater numbers of fleet drivers will soon (and already have) invest(ed) in idle-reduction equipment. To help spread the word, three levels of marketing and outreach were conducted during the project period, each targeted at specific stakeholders. Marketing activities were targeted at the following three areas: drivers who travel through Wilton, the government, and the trucking industry in general.

Direct marketing to drivers was conducted at the site through a number of activities including: installing informative signs at the entrance to the Wilton Travel Plaza, placement of brochures in the convenience store and restaurant, offering (no service charge) complementary services, and an incentive program to encourage Wilton employees to inform drivers about the Shurepower system. Signs are currently displayed at the entrance to the parking area, on the utility building, and near the payment kiosk at the rear of the parking area. Signs were also posted in the restrooms for several months above the urinals. The tri-fold brochures attached as **Appendix C** were available in the convenience store during the entire demonstration period and “tent” displays were placed on the tables in the restaurant for several months.

From December 2004 through February 2005, an employee incentive program was instituted to reward employees for informing drivers about the Shurepower system. Each time a Wilton employee was able to get a new driver to sign up for the service, they received one entry to win a monthly monetary prize. The more entries one received, the better the chance for them to receive the prize, but it still gave employees with very little interaction with drivers (and therefore fewer entries) a chance to win the prize. Each prize was valued at \$250; two prizes were given in December, and one for each month in January and February 2005. The incentive was originally intended for the employee with the greatest number of driver applicants as described in the employee fact sheet shown as **Appendix D**, but after consultation with the owner of Wilton Travel Plaza, Frank Parillo, it was decided that all employees should have a chance at winning the prize. Therefore, the incentive was modified to a random drawing.



**Figure 13. Sign as Drivers Enter the Truck Parking Area**



**Figure 14. Sign at the Back of the Truck Parking Area**

Technology transfer activities and marketing to government entities were primarily achieved by attending government related conferences and other events. Throughout the project period, the project team including Antares and Shurepower, presented or exhibited at the following government events:

1. Transportation Research Board, January 2004, Washington, D.C.
2. National Idling Reduction Conference, May 2004, Albany, NY
3. SAE Government Industry May 2004 and 2005, Washington, D.C.
4. Iowa I-35 Corridor Alternatives to Truck Engine Idling Workshop, June 2004
5. Texas Idle Reduction Conference 2004
6. Oregon Truck Idle reduction Workshop, July 2004
7. EPA AirInnovations, August 2004, Chicago, IL
8. Clean Cities of Connecticut & Ocean States, October 2004
9. Greater Long Island Clean Cities Community, October 2004
10. NYSMTA Central New York Winter Meeting November 2004
11. RPI Graduate Transportation Engineering Program March 2005
12. EPA West Coast Diesel Emission Reduction Collaborative Public Workshop, March 2005, Seattle, WA
13. Clean Cities Conference, May 2005, Palm Springs, CA
14. NYSMTA Annual Meeting, May 2005
15. Arizona Idle Reduction Workshop, June 2005
16. ITS-NY Annual Meeting & Technology Exhibition, June 2005
17. ITS-CT Annual Meeting, September 2005
18. Greater Long Island Clean Cities Community, September 2005

The project team also attended or exhibited at the following general trucking industry events:

1. The North American Tuck Show, April 2004, Baltimore, MD

2. The Truck Show Las Vegas, June 2004 & 2005
3. The International Trucking Show, September 2004, Anaheim, CA
4. National Association of Truck Stop Operators (NATSO), February 2005, Nashville, TN
5. Mid-America Truck Show March 2005, Louisville, KY
6. Great American Truck Show August 2005, Dallas, TX
7. SAE Commercial Vehicle Conference and Exhibition 2004 & 2005



**Figure 15. National Idle Reduction Conference  
May 17-19, 2004**



**Figure 16. Mid-America Truck Show  
April 1, 2005 – Dometic Booth**

By attending the above events and through discussions with drivers, the project team found that almost everyone agrees that shore power is the best long-term solution to idling. It provides the greatest overall benefits in terms of energy use, emissions, and cost. However, the primary negative feedback always relates to the lack of widespread infrastructure. Many owner operators and fleets are unwilling to invest in higher end shore power equipment without a national network of shore power facilities. If drivers could take advantage of connecting to shore power at most locations where they stop, it would be the most cost effective idle-reduction solution available today, as shown later in this report.

## **Section 3 - PROJECT BENEFITS**

### **ENERGY BENEFITS**

According to the Argonne National Laboratory, long-haul trucks idle on average approximately six hours per day and 1,830 hours per year. USDOE estimates that long-haul tractors burn an average of 1 gallon of diesel fuel per hour when idling. Over the course of the reporting period, more than 2,100 gallons of diesel fuel were saved. Each gallon of diesel fuel has an energy content of approximately 38 kilowatt-hours (130,000 Btu) per gallon.<sup>4</sup> If this diesel was used to produce electrical energy at only 35% efficiency, over 28,000 kilowatt-hours could be produced. Therefore, even if overhead facility energy is included, the project saved over 18,000 kilowatt-hours of energy during the reporting period.

It is also important to note that most of the power consumed from resting truck drivers occurs at night, which is an “off-peak” electrical consumption period. This increases overall energy consumption, but simultaneously increases the efficiency of existing power generation facilities in New York. Additional electricity generation capacity is not required, but additional electricity is sold, thereby increasing profits to New York power providers.

### **ENVIRONMENTAL BENEFITS: EMISSION REDUCTIONS**

Using TEP can eliminate noise and tailpipe emissions produced by large idling sleeper cab tractors. Idling trucks produce emissions as a stationary source since the power is not being utilized for transport. The Truck Maintenance Council (TMC) of the American Trucking Association (ATA) estimates that 10 seconds of engine idling generates as much emissions as restarting the engine.<sup>5</sup> In addition, it has been estimated that a single long-haul truck idling for 1,830 hours per year emits 220 pounds of nitrogen oxides; 380 pounds of carbon monoxide; and 20,300 pounds of carbon dioxide (a greenhouse gas).<sup>6</sup>

The following table summarizes the diesel fuel and emissions saved over the reporting period. Emission factors were found in an SAE submitted by Oak Ridge National Laboratory and EPA.

---

<sup>4</sup> [www.eia.doe.gov](http://www.eia.doe.gov)

<sup>5</sup> *L-P Tardif & Associates Inc., 1999*

<sup>6</sup> Argonne National Laboratory



**Table 2. Emission and Fuel Savings**

<b>Month</b>	<b>Diesel Fuel</b>	<b>NOx pounds</b>	<b>PM pounds</b>	<b>CO<sub>2</sub> pounds</b>	<b>CO pounds</b>	<b>HC pounds</b>
Aug-2004	36	10.7	0.3	753	6.2	3.5
Sep-2004	44	13.0	0.4	913	7.5	4.2
Oct-2004	25	7.5	0.2	528	4.3	2.5
Nov-2004	177	52.6	1.4	3692	30.2	17.1
Dec-2004	198	59.0	1.6	4145	33.9	19.2
Jan-2005	245	73.0	2.0	5125	42.0	23.8
Feb-2005	208	62.0	1.7	4354	35.7	20.2
Mar-2005	321	95.4	2.6	6697	54.8	31.1
Apr-2005	95	28.3	0.8	1989	16.3	9.2
May-2005	285	84.8	2.3	5953	48.7	27.6
Jun-2005	57	17.0	0.5	1195	9.8	5.5
Jul-2005	167	49.7	1.4	3486	28.5	16.2
Aug-2005	283	84.4	2.3	5921	48.5	27.5
<b>Total</b>	<b>2142</b>	<b>638</b>	<b>17.4</b>	<b>44751</b>	<b>366</b>	<b>208</b>

**ECONOMIC BENEFITS**

TEP offers a partial solution to the increasing reliance on petroleum supplies from outside the State and Country. By utilizing shore power rather than refined petroleum products, the tractors reduce their idling and keep more money within the state and region. This helps to grow the local, state and regional economy. Considering that the majority of TEP users are from out-of-state, TEP should also have a positive effect on net money flow into the State. In addition, TEP will provide business for local electrical distribution hardware vendors, local contractors for construction, installation, maintenance and repair, and a future opportunity for State-based firms to design and manufacture specifically-tailored TEP hardware to serve State and national markets. The retrofit installation of the HVAC and inverter/charger systems could represent a substantial market for firms like NTR that are located within the State. The biggest financial impact may be the potential development and location of a national TEP concessionaire firm within the state. This latter development would bring many higher-level business management, marketing and sales jobs into New York State. Another economic benefit to the State which should be emphasized but is difficult to quantify is the cost impact of a reduction in truck accidents on state highways due to more rested and alert truck drivers. This benefit may far outweigh any other direct economic benefits in terms of total impact on the state.

The TEP host-sites will also generate a new source of revenues from their parking lot which generally costs the owners considerable cash to maintain. The host-site will receive a percentage of the service fees based

on gross revenues. Additionally, the host-site could generate additional revenues through the sale of shore power related equipment and other 120-VAC appliances. Facilities with service centers could also install electric HVAC systems and wire distribution kits.

Shore power TEP is an economically viable solution to idling. Capital infrastructure costs are two to five times lower than off-board TEP and end user costs are considerably lower as well. **Table 3** compares off-board TEP to shore power TEP. An end user cost comparison is attached as **Appendix E**.

**Table 3**

TEP System Comparison			
		Shorepower TEP	Off-Board System
<b>Infrastructure</b>	<b>Construction/Upgrades</b>	<b>Moderate</b>	<b>Extensive</b>
	<b>Aesthetic Impact</b>	<b>Minimal</b>	<b>Significant</b>
	<b>Cost per Unit</b>	<b>\$3,000 - \$7,000+</b>	<b>\$16,000 - \$25,000</b>
	<b>Parking Area required</b>	<b>None in many situations</b>	<b>10 – 20%</b>
	<b>Maintenance &amp; Operation</b>	<b>Low</b>	<b>Moderate</b>
<b>System</b>	<b>Usage</b>	<b>Anywhere there is an outlet</b>	<b>Only at travel plazas where there is infrastructure</b>
	<b>On-site Personnel</b>	<b>None required</b>	<b>Full-time</b>
	<b>Difficulty of Installation</b>	<b>Low - simple plug-in <i>Now offered as standard equipment on several models</i></b>	<b>Moderate - may require 2 people to install console</b>
	<b>Energy Use (estimated average.)</b>	<b>1.5 kW</b>	<b>2.0+ kW</b>
	<b>Service Cost per Hour</b>	<b>\$1.00</b>	<b>\$1.88 (Basic services)</b>
	<b>Environmental Impact</b>	<b>Both systems significantly reduce energy and emissions from diesel idling</b>	
<b>On-board</b>	<b>Engine &amp; vehicle maintenance</b>	<b>Both systems significantly reduce engine maintenance requirements due to reduced idling</b>	
	<b>Fuel Savings</b>	<b>Both systems reduce diesel fuel consumption from idling by approximately 1 gallon per hour</b>	
	<b>Equipment Cost</b>	<b>\$189 - \$3,000+</b>	<b>\$10 template</b>

Drivers using the STEP facility were generally very happy with the services. Drivers only consistently complained that there is not enough truck parking areas with shore power. Due to the relative low volume production of dedicated electric shore power HVAC systems, prices are higher than comparable systems from the residential and recreational vehicle markets. One factor contributing to the cost relates to durability and the requirement for heavy-duty components that can withstand hundreds of thousands of miles in the harsh environment of a long-haul truck. As a low cost alternative, one driver for Schneider chose to adapt an in-wall residential unit to his truck window by fabricating a bracket that temporarily holds the unit in place while he stops at the Wilton Travel Plaza; he says, “I love it!” Another driver raved that he simply plugs a portable heater in when it gets cold and claims to, “have had no problems with it.” These drivers and many others saved over \$25 dollars per night by using the STEP system. If shore power was used 300 days per year at this rate, \$7,500 per year could be saved.

## Section 4 - CONCLUSIONS

Overall, the project progressed well and accomplished demonstrating both the on-board equipment and the infrastructure required for shore power truck electrified parking. Although, 100% utilization and conversion of the entire long-haul sleeper cab population was not achieved, the project partners were able to make many stakeholders aware of the many benefits of shore power TEP. It is clear that a single shore power TEP facility is not enough to encourage widespread utilization of the technology. However, project partners gained an extraordinary amount of experience through conducting this project which ultimately resulted in Shurepower, LLC of Rome, New York applying and receiving a grant from NYSERDA to start a New York based business focused on deploying shore power TEP throughout New York and the Nation. By doing so, Shurepower will continue to help reduce petroleum consumption, energy waste, exhaust emissions, noise and traffic safety issues. As an added benefit, drivers can enjoy the conveniences of their homes with cable television and Internet connections, and ultimately get a restful night's sleep. Access to communication services will also allow drivers to avoid traffic which can reduce on-road idling and increase the efficiency of operations.

A National or regional network of shore power facilities is required to fully address the chicken-or-egg dilemma. Without the infrastructure, most drivers may not be willing to purchase the higher level on-board equipment packages. Conversely, shore power implementers may not be willing to invest in the shore power infrastructure without greater numbers of shore power capable sleeper-cabs. Investments in the future made by progressive thinkers such as NYSERDA, NYSDOT, USDOE, and EPA, will help Shurepower address the infrastructure side of the equation. In fact Shurepower is currently under contract to deploy 11 new shore power facilities in New York, Oregon, Washington, Texas, and Pennsylvania. Fleets are also beginning to realize the benefits of shore power by installing shore power equipment at their own terminals and warehouses. The combined facilities will help rapidly expand the shore power network within the trucking industry. Shore power technologies are also conducive to queuing areas at ports and boarder crossings where trucks typically “creep” forward while they wait in line idling. Staging areas at new or existing parking areas in close proximity to the facility could be set up with shore power pedestals to allow drivers to reduce idling. Drivers could then use cell phones or be given pagers to notify them when they are permitted to enter the area.

Although the Sponsors and project partners support all anti-idling devices, shore power truck electrified parking provides the greatest overall benefits when compared to other idle reduction technologies. Shurepower TEP is more cost effective for drivers and fleets and requires less capital to implement and operate. Overall energy consumption and emissions are also the lowest of all currently available idle-reduction technologies, as shown in an ANL poster (**Appendix F**). Emissions benefits could be even lower through the use of renewable resources for electric generation.

# Appendix A

## Shurepower Vehicle Suite

### Integrated Tractor Shore Power Retrofit Kit

### User Manual



**CAUTION:** The Shorepower Vehicle Suite uses power from a 120/240 volt power source. The potential for lethal electrical shock is present. Inadvertent shorts could result in damage and/or personal injury. All servicing of this system should only be done by a qualified service technician. Always disconnect the 120/240 volt power supply when performing routine maintenance, cleaning, or servicing the vehicle.

The Shorepower Vehicle Suite allows the long-haul truck driver to plug into a 120-volt (sometimes referred to 110-volt) or 240-volt (sometimes referred to 220-volt) grid power supply to power alternating current (AC) vehicle loads. The Shorepower Vehicle Suite retrofitted to your vehicle includes a: shorepower supply line, heating ventilation and air-conditioning (HVAC) system, coffee maker, TV-DVD combination, microwave oven, 120-volt AC receptacles, and a load management system. Exterior receptacles for cable TV, Internet, telephone and AC block heater power supply are also included with the suite of equipment. The Shorepower Vehicle Suite is designed to provide a comfortable living space when connected to an AC power supply.



**Figure 1.** Phone/ Cable/ Internet receptacles, and Shorepower line access

**Note:** Owner’s manuals for the individual components included with the Shorepower Vehicle Suite are included at the end of this document and provide a detailed description of their operation (**Appendix A.**)

The Shorepower Vehicle Suite is designed to be used with a 50-amp, 240-volt 4 prong plug configuration (NEMA 14-50P) as shown in **Figure 2**. A 50-amp power supply will provide maximum power for your on-board power requirements. If this type of outlet is not available, the supplied “dog-bone” adapter (**Figure 3**) can be utilized to plug into a 30-amp, 120-volt power supply. The Shorepower Vehicle Suite can also be powered with a traditional household outlet with the use of the supplied 120-volt adaptor displayed in **Figure 4**.



**Figure 2.** 50-amp, 240-volt plug (14-50P)

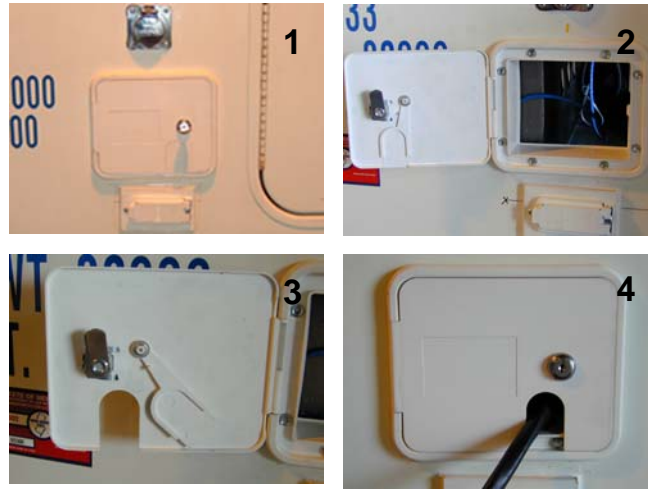

**Figure 3.** 50 to 30-amp Dog-Bone Adaptor



**Figure 4.** 120-volt adaptor

Before connecting the main shorepower line to a power source, feed the line through the small access door located on the drivers side of the vehicle next to the storage door (**Figure 1.**) Once the shorepower line is extended to the appropriate length to reach the power source, the small access door can be closed and locked for security with the shorepower line protruding through the slot in the access door (**Figure 5.**)



**Figure 5.** Use of the shorepower line access door

**WARNING:** Whenever connecting or disconnecting any power source to the vehicle, use caution and avoid touching the prongs on the plug. Severe injury or death could occur if the pins are touched. The supply side breakers should always be in the OFF position whenever connecting or disconnecting any plug to decrease the likelihood of injury. **Figure 6** shows a typical power pedestal with built in breakers. Every attempt should be made to keep connections off the ground and shielded from snow, water, and the elements, to avoid electrical shorts and shock hazard.



**Figure 6.** Lift cover to view breakers and outlets. Always turn breakers to the OFF position before plugging in or removing any plugs

Once the main shorepower connection is made, the breaker(s) may be engaged to the ON position.

**Note:** Many household 120-volt outlets are fused at 15-amps. These outlets should not be used to power the Shorepower Vehicle Suite at the risk of tripping the breakers and creating a potentially hazardous situation. Kitchen and garage outlets are typically fused with 20-amp breakers and therefore are a better candidate for use with the Shorepower Vehicle Suite.

**Intellitec Smart EMS**

The Shorepower Vehicle Suite comes equipped with an Intellitec Smart Energy Management System (EMS). When 120-volt AC power is supplied to the vehicle, the Smart EMS will monitor the total amperage draw of the vehicle and limit the current to a 30 or 20-amp threshold. The current draw is displayed on the EMS display as shown in **Figure 7**. Once the current draw reaches the predetermined threshold, the Smart EMS will cut power to (or shed) non-critical loads. **Table 1** displays the load shedding sequence. Once a load is shed, it will remain off for a minimum of 2 minutes after current drops below the threshold.

**Table 1 - Intellitec Smart EMS Load Shed Order**

Component	Shed Order
HVAC	1
Inverter	2
Exterior Outlet	3
Microwave	4

The Smart EMS is automatically set to limit current to 30-amps when 120-volt service is detected. When using a common household outlet and the adaptor shown in **Figure 4**, the black button on the Smart EMS **must** be pressed to limit current to 20 amps. Once the button is depressed, the green '20 AMP' LED will illuminate.



**Figure 7.** Smart EMS Display. 30/20 AMP SELECT button circled in red

The Smart EMS will automatically recognize when a 50 amp 240-volt power supply has been connected to the vehicle. Since the 50 amp connection is sufficient for all your electrical needs, the load shed feature will not be required and therefore will be automatically disabled.

### **Cab Comfort Duo-Therm HVAC System**

The Shorepower Vehicle Suite is equipped with a Cab Comfort Duo-Therm heating, ventilation, and air conditioning (HVAC) system. The HVAC system is controlled with the remote display attached to the back side of the closet/television cabinet (**Figure 8.**) Fan speed and temperature can be adjusted with the remote panel attached to the wall with Velcro, which is removable for your convenience. The HVAC unit is the highest energy load installed with the Shorepower Vehicle Suite and is the first load to be shed by the Smart EMS when total current reaches the preset threshold.



**Figure 8.** Cab Comfort HVAC remote/ display mounted behind the clothes/ TV cabinet

When connected to a 120-volt power supply you may hear the HVAC system cycling on and off. Two factors can cause this: 1.) the temperature setting on the remote display has been reached, or 2.) the current limit setting of the Smart EMS has been reached. If a comfortable temperature has not been reached and the HVAC system cycles off, you may try turning off other high power loads to reduce the overall current draw. **Table 2** shows the power requirements of the components installed with the Shorepower Vehicle Suite and other common accessories. Limiting the higher loads at the top of the table will promote the HVAC system to re-energized after the 2-minute delay.



**Table 2 - Component Power Consumption**

Installed Component	Peak Power (watts)	Current @ 120 V (amps)
Cab Comfort HVAC	1800	15.0
Block Heater	1500	12.5
Dometic Microwave	1000	8.3
Black & Decker Coffee Maker	650	5.4
Sylvania TV/DVD Combo	80	0.7
Tundra Refrigerator	40	0.3
<b>Other Components</b>		
Vacuum	1100	9.2
3/8" Drill	500	4.2
Blender	300	2.5
Lamp	100	0.8
Laptop computer	50	0.4

**Xantrex Inverter/Charger**

The Shorepower Vehicle Suite is equipped with a Xantrex Inverter/Charger. Loads connected to the inverter can be used for short periods of time without a shorepower connection. As delivered, the inverter powers the TV/DVD, coffee maker, and the refrigerator. However, any accessory plugged into the outlet behind the TV/DVD, the outlet mounted behind the TV/clothes cabinet (above the bunk), or the outlet used for the refrigerator and coffee maker can be utilized when the main shorepower line is not connected to an AC power source.

When the main shorepower line is connected to an AC power source, the inverter/charger is capable of charging the vehicle batteries. The green “CHARGE” LED on the Xantrex display will illuminate when the battery charger is ON and charging as shown in **Figure 9**. If connected to an AC power source and the green “CHARGE” LED is not illuminated, press the “CHARGE” button to charge the batteries. The green “INVERT” LED must be illuminated to power the TV, refrigerator and coffee maker outlets. If the LED is not illuminated, press the “INVERT” button on the Xantrex remote display panel (**Figure 9**.)



**Figure 9.** Xantrex Remote display Panel

When the main shorepower line is not connected to an AC power source, loads will run off battery power until:

- 1.) The vehicle is connected to an AC power source.
- 2.) The “INVERT” button is depressed and the inverter function is off.
- 3.) The battery is drained of starting power.

**Caution:** Using the inverter to power your vehicle loads will deplete the battery energy storage. Extended use of the inverter is not recommended with regular lead-acid batteries as this may permanently damage the batteries when not connected to an AC power supply. Additionally, battery voltage could drop below levels required to restart the engine. Deep cycle batteries are recommended if you wish to use battery power for prolonged periods of time.

### **Other Components**

The Tundra refrigerator supplied with the Shorepower Vehicle Suite is always ‘ON’ unless it is unplugged or the green INVERT LED is not illuminated. To avoid draining the batteries, the refrigerator should always be unplugged when it is not being used or if the vehicle is not connected to an AC power source. Switching OFF the INVERT function will also disable the refrigerator. To avoid draining the batteries, make sure the green INVERT LED is not illuminated.

**Note:** The refrigerator will not remain cold if it is unplugged, or the ‘INVERT’ button is not illuminated. Perishables should not be stored in the refrigerator when it is not powered.

The block heater installed on your vehicle can be used by plugging into any 120-volt power supply. The receptacle for the block heater is located on the driver’s side lower front fender, as shown in **Figure 10**. If an additional outlet is not available to power the block heater, the external power receptacle located at the rear of the tractor (**Figure 11**) can be used to power the block heater. Simply connect the exterior receptacle to the block heater receptacle with a heavy duty extension cord. Use of the exterior receptacle should only be used when the vehicle is connected to a 240-volt power source or a 120-volt, 30 amp power source. A 120-volt, 20 amp household receptacle will not provide enough power for both the block heater and HVAC system; therefore the performance of the system will suffer.

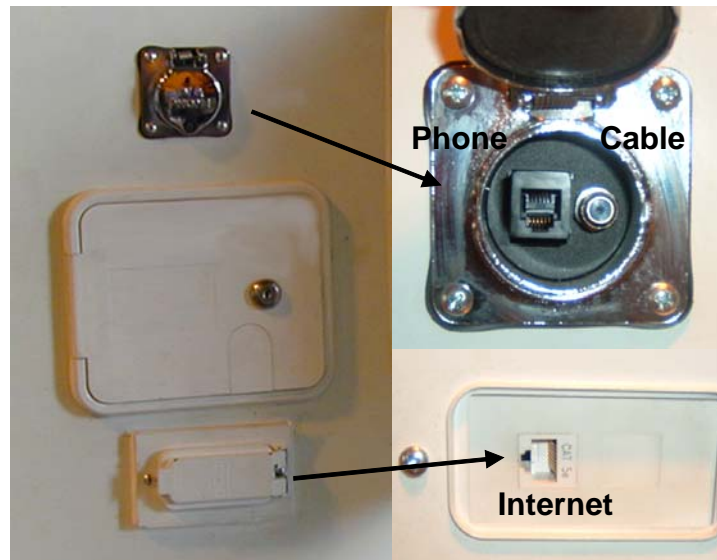

**Figure 10.** Block heater receptacle mounted on driver's side fender



**Figure 11.** Exterior 120-volt receptacle located at rear of cab

Phone, cable TV, and Internet lines can be connected to the vehicle through the exterior receptacles shown in **Figure 12**. Your vehicle has been pre-wired with interior wall receptacles for phone, cable and internet. The interior cable TV receptacle is located behind the TV-DVD combination unit. The connection from the interior receptacle to the television should already be in place; therefore, only the exterior cable receptacle should require a connection to a cable source. Similarly, phone and Internet supplies must be connected to the exterior receptacles in order to use these services inside the cab. The interior phone and Internet receptacle is located behind the refrigerator cabinet, next to the bunk. Use of telephone and Internet services will require the use of your own phone and computer; they are not included with the Shorepower Vehicle Suite.



**Figure 12.** Cable, Phone and Internet connections

## Troubleshooting

With the main shorepower line connected to the vehicle, AC power should be available for all your in cab power requirements. If any items do not appear to be functioning properly, please check the following:

- 1.) Make sure all the breakers on the main Intellitec panel (located under the bunk on the passenger side as shown in **Figure 13**) are in the ON position.



**Figure 13.** Intellitec breaker panel (A) and HVAC outlet (B) located under the bunk

- 2.) Verify that the component is plugged into an interior wall receptacle,
- 3.) Ensure that the component is turned on.
- 4.) Make sure the main shorepower connection is securely plugged into an AC power source.
- 5.) Check that the breaker(s) from the power source is in the ON position as displayed in **Figure 7-A**. If connected to a residential or commercial building, this may require access to the main breaker panel, usually located inside the building.
- 6.) Inverter loads require that the green “INVERT” LED be illuminated on the Xantrex inverter remote display,
- 7.) The Intellitec Smart EMS load shed feature may be operating. Turn off all unnecessary components and wait a minimum of 2 minutes to see if the component powers up. You may be required to turn the component ON after the 2 minute interval.
- 8.) If the load shed feature is operating and the vehicle is connected to a low current source, or there is a high level of loads used in the vehicle, you may be required to plug into a higher capacity receptacle. If a higher capacity power source is not available, you may also try turning off all components and waiting a minimum of 2 minutes before attempting to re-power the most desirable component.
- 9.) The Cab Comfort HVAC system is equipped with its own circuit breaker and is plugged into an outlet equipped with a circuit breaker (**Figure 13-B**.) If the HVAC system is not functioning check these breakers in addition to the breakers located on the Intellitec breaker panel.
- 10.) The Xantrex inverter/ charger is also equipped with its own push button breaker. If the inverter/ charger is not functioning, push the button on the face of the unit and check the breaker on the main Intellitec breaker panel.

Please direct additional questions to:

**Shurepower LLC**

153 Brooks Road  
Rome, New York 13441  
Jeff Kim  
(503) 892-7345  
Joe Licari  
(315) 404-5613

**ANTARES Group Incorporated**

Chris Lindsey  
4351 Garden City Drive  
Suite 301  
Landover, Maryland 20785  
301-731-1900

**Appendix B**

**Shore Power On-Board Suite**

**Installation Manual**

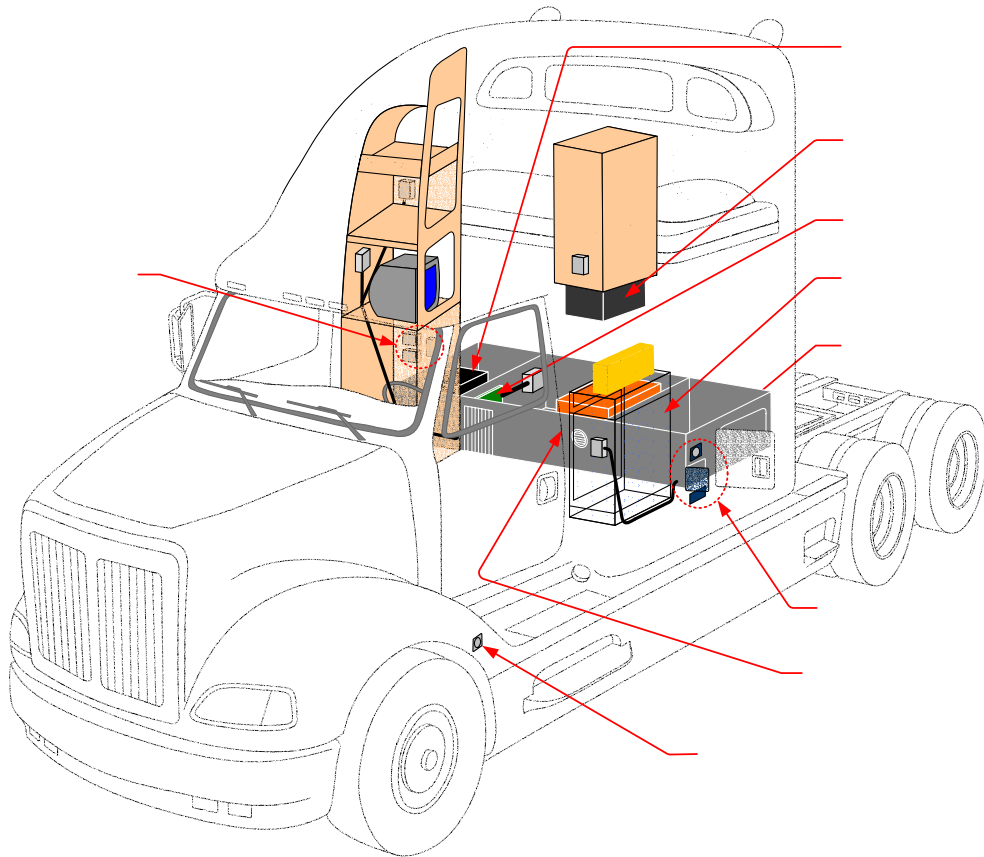

## Background

This manual serves as an overall guide for installing a Shorepower equipment suite on a Class 8 long-haul tractor as a retrofit option. The manual covers instructions for laying out the system, and installation steps for each component. However, the original equipment manufacturer's installation manuals should be read before starting since the installation of the individual components is covered in more detail and contains all of the necessary safety warnings.

Each piece of equipment will have most of the hardware needed for installing them; however, some miscellaneous hardware such as bolts, electrical tape, and wire loom will be needed. The installation requires the use of standard shop tools such as a drill, drill bits, hole saw, reciprocating saw, screwdrivers, measuring tape, and a multimeter.

The expected time to complete the installation depends heavily on the prior experience of the mechanic/technician performing the installation. The inexperienced installer will take the longest time. However, the intent of this manual is to help guide the process to avoid pitfalls and reduce the learning curve for a first time installer. After gaining the experience of several installations, the whole installation should take approximately 10-12 labor hours or 8-10 hours without the accessories.

## Installation

### ***Selecting Hardware Mounting Locations***

The first step of the installation is to survey the layout of the truck cab to determine the best locations for the hardware, outlets, and accessories. The hardware must be installed inside the cab to protect it from weather and physical damage, although space is very limited inside the truck cab. The underbunk area is the preferred location since it is large enough to fit the key on-board Shorepower components, which include an auxiliary heating, ventilation, and air conditioning (HVAC) unit, an inverter/battery charger, and a load management system.

The underbunk area may, or may not be partitioned into compartments. The driver's side of the compartment, or area, is accessible from an exterior access door. This manual was done on a tractor with partitions. Installations on tractors without partitions will allow for more flexibility for locating the equipment. Figure 1 shows an example of the layout along with the installation locations used of this truck used for this manual. The dimensions of the major hardware pieces are shown in Table 1. The passenger's side partition may have equipment installed such as parts of the vehicle HVAC system or a communications system (such as a Qualcomm unit); however, this will be different for each truck model. Rearranging the mounting locations of existing hardware pieces may be an option if more floor space is required.

Table 1: Dimensions of Major Shorepower Hardware Suite Components

	<b><i>Length (inch)</i></b>	<b><i>Width (inch)</i></b>	<b><i>Height (inch)</i></b>
<i>HVAC</i>	24.000	16.000	12.250
<i>Inverter</i>	13.200	11.500	7.900
<i>Load Management System</i>	19.563	9.125	7.000
<i>Coffee Pot</i>	13.000	11.000	10.500
<i>Microwave</i>	11.063	17.938	12.313
<i>Refrigerator</i>	20.750	15.500	13.750

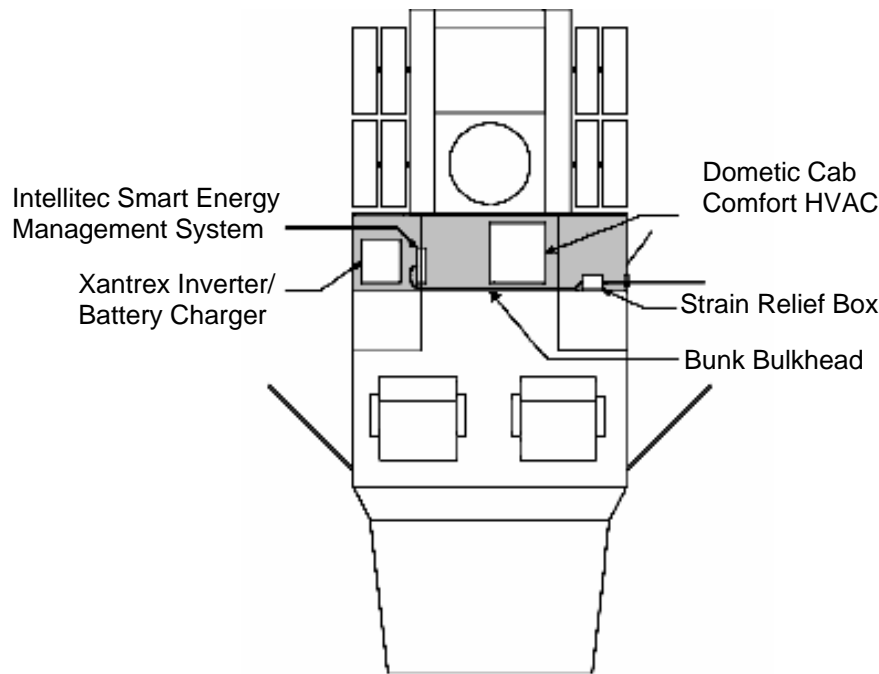

Figure 1: Plan view of truck cab interior with major Shorepower equipment installation locations

The largest pieces of hardware in the on-board Shorepower system are, in order from largest to smallest: (1) the Cab Comfort heating, ventilation, and air conditioning (HVAC) unit, (2) the Xantrex inverter/battery charger, and (3) the Intellitec Smart Energy Management System Distribution Panel/Breaker Box (Intellitec). The remaining pieces such as wiring, electrical outlets, and remote panels for the major components are much smaller and acceptable installation locations are not difficult to find. The HVAC unit is the largest piece and should be given priority. The unit will probably be too large to fit into the smaller spaces, and will have to be installed in the large center section. The unit should be offset to one side of the compartment, depending on the location of the remaining hardware in order to maintain the maximum free space.

The Xantrex inverter is the second largest and heaviest component and should be installed next. The inverter handles a large amount of electrical power, so the ideal location would be out of the way of normal driver activity. The underbunk partition on the passenger's side is ideal if large enough, since it is isolated and not typically used by the driver for storage.

The last critical piece of hardware is the Intellitec Smart Energy Management System. The ideal mounting location for the distribution panel is the same as for the inverter so that it is as isolated as possible from normal underbunk activity. A good mounting location is on the partition wall between the passenger's side and center partitions, if equipped, with the breakers facing into the center partition. Figure 2:1 shows the underbunk installation with the Intellitec mounted on the left hand side. This safely contains the high power wiring (distribution panel and inverter) in the most isolated and least used underbunk partition. This location also allows for very short wiring runs between the inverter and load center. Mounting the panel upside down is an option so that the screw terminals on the breakers face upwards to make it easier to connect the wires. The location and number of the electrical outlets will be determined based on how each of the accessory loads (e.g. TV, microwave, refrigerator, etc.) are controlled by the load center. The maximum number of outlets is determined by the available breakers, although the system rating will not change. Preliminary mounting locations for the block heater, exterior 120VAC (alternating current) auxiliary outlet, and entertainment wiring receptacles should be identified





Figure 2: Installed Cab Comfort HVAC unit (left); Installation of optional flexible 4" air outlet ducting

even though they will be installed after the major hardware components are installed. The installation location for the remaining miscellaneous items such as the entertainment wiring (cable TV, Internet, and phone) and equipment remote control panel (Xantrex inverter, Intellitec, and Cab Comfort HVAC unit) mounting can be identified after the main system components have been installed.

### ***Cab Comfort HVAC Unit Installation***

The first step is to read the manufacturer's installation instructions. The Cab Comfort HVAC unit is a heat pump that provides heat and air-conditioned air. The heat pump is not able to keep the cab warm when the temperature drops below 30°F, so the unit can be equipped with an optional resistance heater. The unit is 12 ¼" high, 16" wide, and 24" long and is designed to fit in the underbunk area. The unit should be positioned close to the storage area bulkhead divider wall so the air discharge adapter fits into the discharge air outlet grill that will be installed later as shown in Figure 2. If it is not possible to position the unit like this, a length of flexible 4" dryer vent ducting with hose clamps can be used to connect the discharge nozzle and the discharge vent (FIG 2:2). The side of the unit with the resistance heater (shown on the right (driver's) side of the unit in Figure 2:2) must have 4" of clearance. Following the installation instructions, attach the resistance heater if not already attached to the HVAC unit.

The underbody of the underbunk floor area needs to be inspected before the floor is cut so that the floor braces and hidden electrical wiring are not cut creating safety issues (FIG 3). Two 1¼" drain holes, one 4" by 4" discharge air hole, and one 15 1/8" by 2 ¾" inlet air hole need to be cut in the floor beneath the unit as shown in Figure 4. Use a template to locate and cut out the holes in the floor for the HVAC system (FIG 5). Mount the



Figure 3: Underbody inspection for HVAC location selection

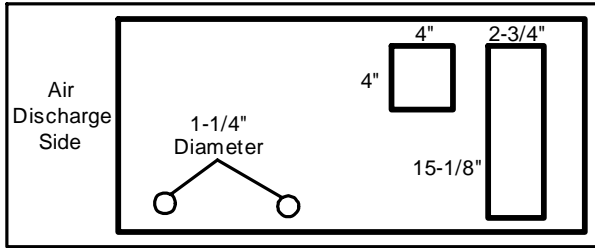

Figure 4: HVAC floor hole locations

grills for the condenser supply and return ducts. The condenser intake (two plastic parts) and discharge (one plastic part) air ducts are installed by applying a bead of sealant around the floor openings cut using the supplied template and inserting the ducts supplied with the unit into the appropriate holes (FIG 6). Arrange the ducts in such a way to minimize the system picking up residual engine heat when the

vehicle is stopped. Use foam tape or weather stripping around each hole to prevent water from leaking into the cab.



Figure 5: Template and cutting of HVAC drain and air discharge holes

Determine and mark the location of the interior discharge hole on the bunk bulkhead wall. Use a hole saw and/or a reciprocating saw to cut the hole. Use foam tape or weather stripping to seal around the hole. An air inlet or return air vent, which can be a standard household type, needs to be placed in the bunk bulkhead. The white vent shown in the lower left hand corner of Figure 2:2.is the air inlet vent.

The next step is to position the HVAC unit above the drain holes and air ducts. Screws are

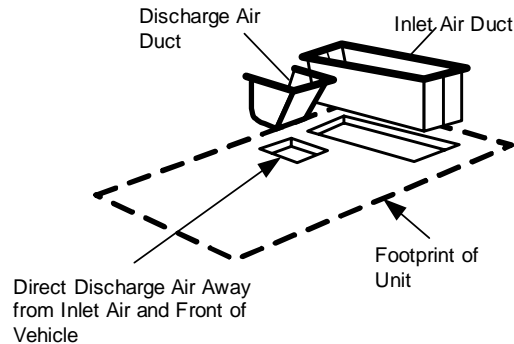

Figure 6: HVAC exterior duct locations

used to secure the unit to the floor. There are four primary mounting tabs and six optional tabs if the primary tabs cannot be used due to space concerns or conflicts with vehicle wiring or other hardware. Both sides of the HVAC unit must be anchored using the tabs provided on the case (FIG 7). The unit requires a 120VAC/15A outlet that will be installed in this underbunk compartment in a later step.

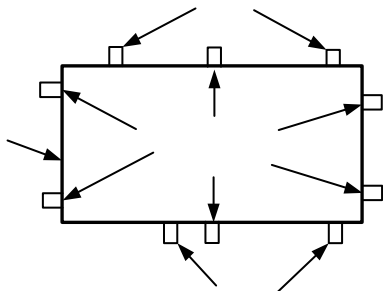

Figure 7: HVAC mounting tab locations

The auxiliary HVAC unit has a thermostat/remote control panel that can be mounted with Velcro® anywhere in the bunk area where it is shielded from heating and cooling sources such as vents and lights, but still receives adequate air flow (FIG 8). Do not mount the panel in a corner or other area where the air is stagnant. The rear wall of the passenger's side storage area offers the most space and is also an ideal mounting location for the remote panels for the inverter, load center, and HVAC system. The control panel is connected to the HVAC unit with a standard RJ11 phone wire. Attach the wire to the RJ11 connector located at the top corner of the unit (FIG 9). Route the RJ11 wire from the HVAC unit to where the panel will be mounted, leaving at least 6" of slack at the panel end. The 6" of slack allows the driver to easily hold the panel to make adjustments. Remove the rear panel on the remote control panel using a screw driver to pry the cover off, and insert the RJ11 cable. Two screws secure the mounting plate to the wall.



Figure 8: HVAC unit remote control panel

The HVAC unit requires the installation of an ignition interlock circuit. The interlock is a 12VDC (direct current) line that is powered only when the ignition key is on and the truck is running. The interlock disables the auxiliary HVAC unit when the vehicle is running since the vehicle's HVAC system supplies the heating and cooling. The 12VDC interlock line can be



Figure 9: HVAC remote control panel control wire connector

connected to any circuit in the truck fuse panel that is only energized while the truck's engine is running. The power plug will be connected once the electrical outlets are installed. The last step to complete the HVAC installation is to perform the system reset and checkout procedures. Check that all of the features of the system operate correctly, such as fan speeds, cooling mode, and heat pump mode. Once this is done, the system electronics must be reset. This is done first turning the HVAC power switch to "OFF". Next hold the "MODE" and "ZONE" buttons down and flip the power switch to "ON". The display should show "FF" until the buttons are released. This confirms that the system electronics have been reset. This procedure must be performed every time the unit is modified in the future. This procedure will enable the system to recognize the updated configuration.

## ***Xantrex Inverter Installation***

Read the Manufacturer's installation instruction manual before proceeding as it contains unit-specific directions and critical safety warnings. Once the Manufacturer's installation manual has been read, installation of the inverter can begin.

The process of identifying the mounting location for the inverter/battery charger was discussed earlier. Prior to mounting the Inverter, inspect the selected mounting site, the underside of the truck cab, and locate the truck battery box. Identify and measure the length of the route required for the cables connecting the Inverter to the truck battery box. The route cannot exceed the length of the cables provided in the DelcoRemy installation wiring kit shown in Figure 10 (10

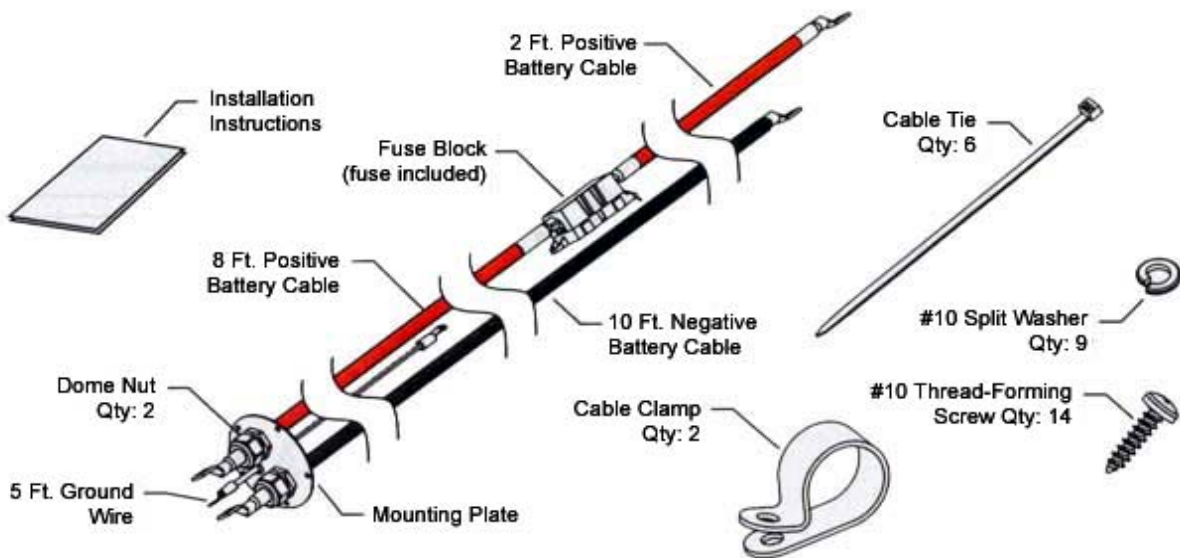

Figure 10: DelcoRemy inverter installation wiring kit contents

feet in this installation). Care must be taken to ensure that structural beams, wiring, and other truck components will not interfere with the Inverter or cabling installation.

The DelcoRemy installation wiring kit includes a mounting plate that seals the area between the cab floor and wires going from the inverter to the battery box. The mounting plate is used to pass the battery cabling through the floor to the outside of the cab and prevent water from entering the cab. Once the inverter mounting location has been finalized, the location for the mounting plate can be determined. A diagram of a typical inverter installation using a DelcoRemy wiring kit is shown in Figure 11. Any floor covering in this area must be removed. Use a hammer and center punch to mark the locations of the pass-through hole and the five mounting screw holes for the mounting plate. Use a 5/32" drill bit for the pilot holes. A 3 1/2" hole saw is used to cut the pass-through hole. Run the battery and inverter ground wires through

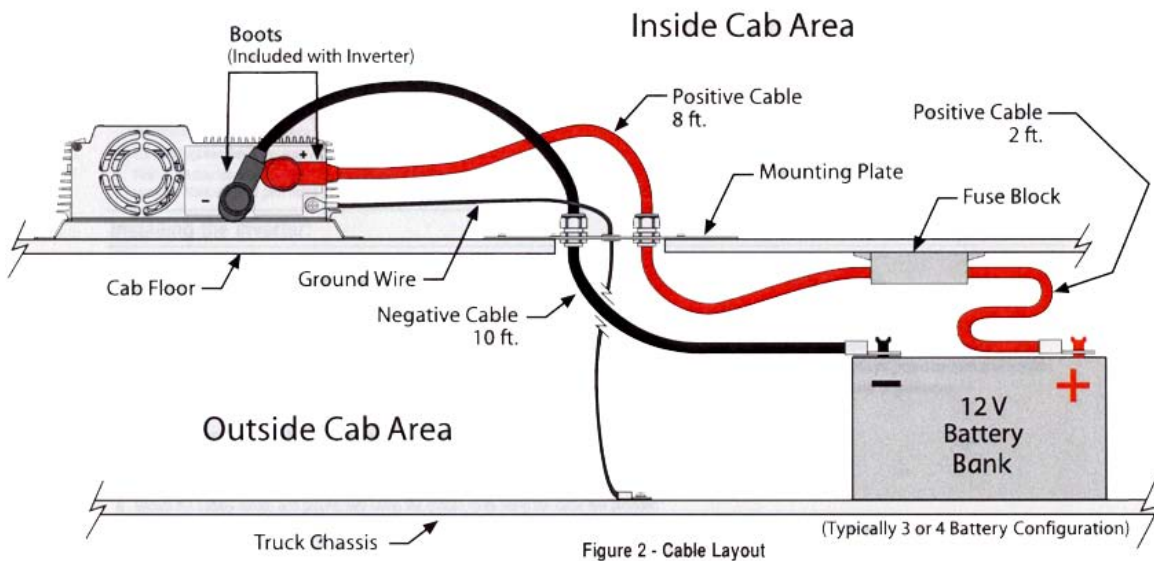

Figure 11: Inverter wiring with DelcoRemy inverter installation kit

the mounting plate (FIG 11). Install the rubber boots included with the inverter on both the positive and negative cable ends on the inverter side as shown in Figure 11. The mounting plate is fastened to the floor next using the screws and washers included in the kit (FIG 12). The positive cable has a fuse block with an inline fuse to protect the inverter from a power surge. The fuse block is 2' from the positive terminal and needs to be mounted to the underside of the body in a convenient location. Determine a mounting location and drill two 5/32"



Figure 12: DelcoRemy mounting plate attached to floor with battery cables routed through, but not attached to inverter

pilot holes for the mounting screws, but do not mount the fuse block yet. This is done after all of the inverter connections have been completed. **DO NOT** connect the positive and negative cables to the battery and inverter. The cables will be connected later to permit the safe connection to the inverter.

The inverter has a battery temperature sensor as a safety precaution. The sensor uses an RJ11 wire with a standard connector on the inverter installed end and the temperature sensor on the battery installed side. Connect the wire to the inverter on top of the front face of the inverter where all of the connections are made (FIG 13). The temperature sensor jack is labeled as "TSC" in Figure 13. A separate hole in the floor or another hole can be made in the DelcoRemy mounting plate to create a path to the battery. A rubber grommet needs to be installed around the hole to create a weather tight seal and to protect the wire from being cut over time by the sharp metal floor. Route the temperature sensor wire to the truck's battery and attach the ring terminal to the positive battery terminal when the inverter connections are made. Wire loom and wire ties should be used to secure and bundle the various wires together.

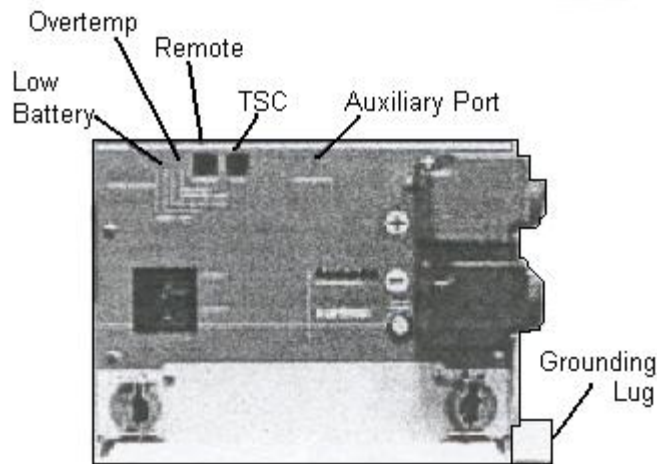

Figure 13: Xantrex inverter front panel

The AC input to the inverter is connected directly to the main bus in the Intellitec (to be installed later). The AC output is connected to the input on a separate bus bar inside the Intellitec for loads run off of the inverter. An example vehicle wiring diagram is shown in Appendix 1 for reference. These loads should be limited to low draw loads like a refrigerator and television unless a large capacity deep-cycle battery pack is used. High power accessories that are typically

run for a short time, such as the microwave or coffee pot, can also be connected to the inverter, but should be used sparingly when not connected to shorepower. Using these devices for long periods will drain the battery; however, short term use of these devices is acceptable.

The inverter has a panel covering the AC lines and electrical connections on the bottom of the front face of the inverter. There is a wire strain relief on either side of this panel to feed the wires through; one for AC input, one for AC output. A custom quick-disconnect setup can be used for the AC power connections rather than hardwiring the inverter to the distribution panel. This type of connection allows the inverter to be quickly and easily disconnected and removed if it requires service or replacement. Any properly rated quick-disconnect positive contact power connectors can be used. One option is to utilize a pair of Phillips & Temro (P&T) power cords (one for inverter AC input, one for inverter AC output) if extras are available to use the quick disconnect connector ends. This option requires cutting the P&T cables to the proper length. Figure 14 shows the installation of the quick connectors on the AC side of the inverter. The first step is to mount the quick connectors on the inverter front panel. Use a male connector for the inverter AC input and a female connector for the inverter AC output. Using different gender connectors here will ensure that the inverter is always connected correctly to the Intellitec. Use wire nuts to connect the connectors to the inverter wiring (FIG 14:3). Screw the front panel on the inverter (FIG 14:4).

The next step is to ground the inverter. The DelcoRemy wiring kit includes a grounding wire that runs through the mounting plate. Attach the grounding wire to the grounding lug on the right side of the inverter inside the cab and to a bare metal portion of the chassis outside the cab as close as possible to the battery ground (FIG 11).

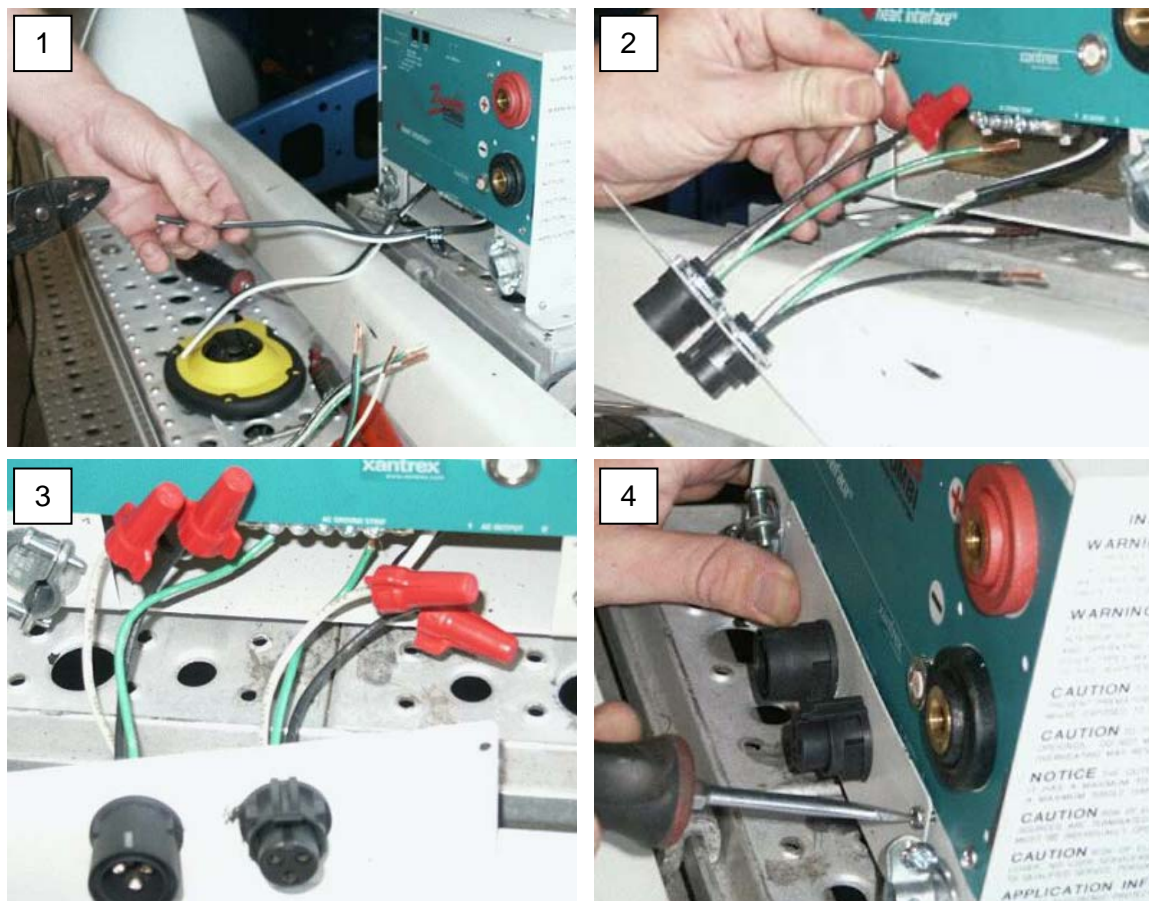

Figure 14: Installation of quick connectors on the AC side of the inverter

The electrical connections between the Inverter and the inverter and the battery are made in the following order:

1. Connect the positive cable to the inverter, tightening the terminal nuts to 10 ft-lbs
2. Place the temperature sensor ring terminal on the positive battery terminal/post
3. Connect the positive battery terminal
4. Connect the negative battery terminal
5. Connect the negative cable to the inverter, tightening the terminal nuts to 10 ft-lbs

Secure the battery cables with zip ties and wire loom. The inverter and fuse block are mounted using the hardware supplied with the unit. Cable clamps included with the DelcoRemy installation kit are placed approximately 6" from either side of the fuse block for strain relief.

The optional Xantrex Freedom Link remote control panel gives the driver an easy and convenient way of monitoring the system without opening the underbunk storage area to inspect the inverter. The remote panel has a bank of status indicator LEDs and is mounted to a wall (FIG 15). The panel is connected to the inverter with a standard RJ11 wire in the jack to the left of the temperature sensor (FIG 13). The panel can be mounted anywhere that is convenient; however, the ideal mounting location is next to or under the HVAC remote installed earlier. This makes it easy for the driver to use the remote panels for all of the hardware. Connect the RJ11 wire to the remote panel and to the inverter using the standard phone jack connectors on both pieces. Mark the location of the panel and mounting screw holes using the supplied template. Start the panel hole with a hole saw, and finish with a reciprocating saw. Mount the panel using the four screws supplied with the kit.



Figure 15: Xantrex inverter Freedom Link remote control panel

## ***Intellitec Installation***

The Intellitec is a traditional circuit breaker distribution panel, with the added capability of shedding loads if current demand exceeds the capacity of the electrical service. Power is monitored by a small circuit board (the EMS Control Module) that calculates a running average of the power usage. The load shedding feature is accomplished by controlling a series of four AC relays and two low-voltage DC relays (not used in this installation) that interrupt power to circuits in an order defined by the user to keep the power usage below the maximum threshold.

Again, the first step is to read the manufacturer's installation instructions since they are more detailed than what is discussed here and contain all relevant safety warnings. The next step is to determine the system shed order by identifying the electrical loads of the components and accessories that will be used. The EMS Control Module senses the input voltage from the Shorepower connection and disables the load shed feature if 240V service is connected. In this case, the system assumes that the line is a standard 120/240VAC-50A line and will have ample capacity for all loads. Table 2 shows maximum power draw from typical components for reference, but actual component ratings should be used since they vary by manufacturer and model.

Table 2: Maximum power draw from typical components

	<b>Maximum Power Draw (W)</b>
<i>HVAC</i>	1530
<i>Block Heater</i>	1500
<i>Microwave</i>	1000
<i>Coffee Pot</i>	875
<i>TV</i>	65
<i>Refrigerator</i>	40

Certain components are generally used for shorter periods of time, such as microwave ovens or coffee pots. These accessories generally only operate for several minutes at a time. Other components such as the HVAC system are used almost continuously depending on the ambient temperature. The thermal inertia of the heated, or cooled, cab and the air inside the cab allows the HVAC to be shed for the short periods of time. Shedding loads is done to allow for the use of short-term high-power usage items such as microwave ovens if the power demand is too high to allow for the simultaneous use of all components. The HVAC system is automatically re-powered when microwave operation is complete. The system's operation should be nearly invisible to the driver. The shed order is determined with this logic in mind.

An example shed order could be (in order of first loads shed): HVAC system, inverter, and the microwave oven. In such a system, components such as the television, coffee pot, and refrigerator are connected to the inverter, which seems like a bad idea since these are items the driver will probably use the most. However, the inverter automatically draws power from the battery if AC power is not available. The result is that shedding the inverter from the AC power supply will be invisible provided it is for a short time (on the order of minutes, but ultimately depends on the type of battery). The Intellitec installation manual has a series of tables that need to be completed to determine the proper load shed order and jumper combination. The EMS Control Module has jumpers that may need to be modified to properly set the selected shed order.

The proper type and rating circuit breakers need to be selected and installed. Intellitec specifies breaker manufacturers and models that can be used on page 8 of their installation manual. Install the breakers with appropriate current ratings in the distribution panel according to the wiring diagram. An example vehicle wiring diagram is shown in Appendix 1.

The installation location for the panel was determined previously. The distribution panel needs a hole 9 1/8" by 19 9/16" and at least 7" deep to allow for proper cooling and space for wire routing. A template should be used to mark the hole. Use a hole saw to start the hole and finish with a reciprocating saw (FIG 16). Mount the Intellitec in the hole with the ten (10) supplied screws (FIG 17).

The EMS Control Module requires 12VDC power be supplied at the appropriate connector at all times. The module also requires 120VAC or 240VAC at the appropriate pins on



Figure 16: Hole cut in passenger's side partition wall for the Intellitec distribution panel.



the J6 connector as shown in the Intellitec installation manual. The system will not operate if one of these is not connected. This is done to prevent the system from draining the battery when a Shorepower connection is not available. The relays are normally open, so the loads connected to the control relays will not operate unless the board is properly connected. Figure 18 shows the location of the EMS Control Module board in the Intellitec. Note that the box is installed upside down with the breaker screw terminals facing upwards.

**NOTE: Disconnect the power inputs (inverter and Shorepower) from the Intellitec for safety while installing and wiring the system.**



Figure 17: Mounting the Intellitec distribution panel

The short electrical connections between the breakers and the EMS Control Module and the inverter AC input should be made according to the wiring diagram. The remainder of the wiring will be completed after the components have been installed and the power wires have been connected.

The Intellitec remote control panel displays the total current of the electrical service, the real-time current draw, and which loads are being shed. The panel can be located anywhere it is convenient, but the optimal location is above or next to the remote controls for the HVAC and inverter that were previously installed. The panel requires a 2 1/8" by 3 3/4" hole be cut. The control wire is connected

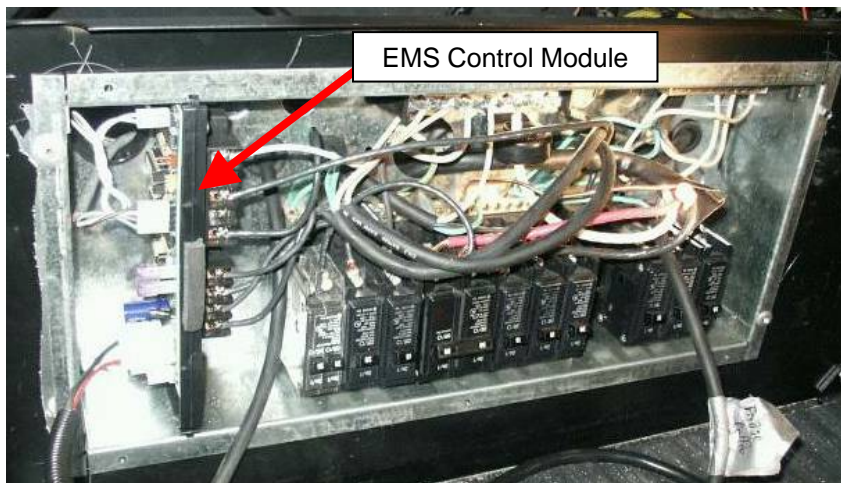

Figure 18: Location of EMS Control Module in the Intellitec distribution panel

to the panel. Fit the panel into the hole with the wire inside the cabinet, or wall, and route it back to the EMS Control Module. Connect the wire to the J5 connector on the EMS Control Module, making sure the polarity is correct. Mount the panel in the opening with two flat head #6 screws. The mounted inverter and Intellitec panels are shown in Figures 19 and 20.

Four feet of 120/240VAC-50A Romex waterproof cable is used to connect the Intellitec to the main power electrical supply cable at the strain relief box. There are 2 hot wires that must be connected to the Intellitec Primary Circuit Breakers, one common wire that must be connected to the common bus bar, and one ground wire that must be connected to the enclosure chassis. The waterproof cable is anchored to the truck cab between the Intellitec and the strain relief box. The 4 wires in the waterproof cable are connected to the wires of a typical 220VAC 4-ft. household range cable at the strain relief box using wire nuts. The 4-ft. range cable is anchored to the truck cab at the strain relief box. By having the two cables connected using wire nuts at the

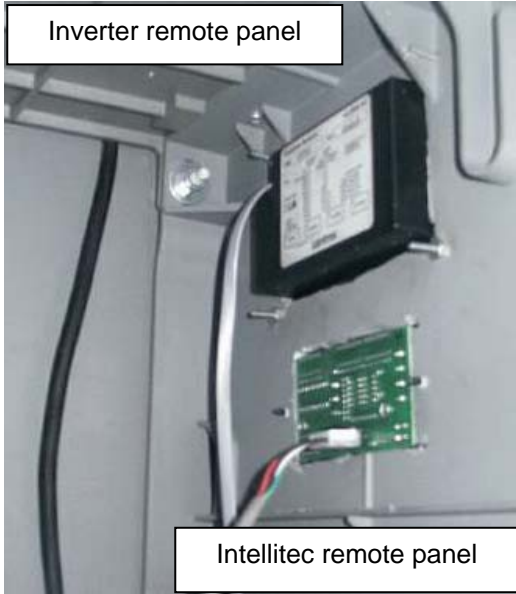

Figure 19: Rear view of inverter and Intellitec remote panel mountings



Figure 20: Front view of inverter and Intellitec remote panel mountings

strain relief box, the truck cab wiring is protected from major damage if the truck is driven away while still connected to the Shorepower pedestal. The final electrical connection between the 4-ft.

range cord connected to the strain relief box and the Shorepower pedestal is made with a 30-ft. RV style 220V-50A extension cord with 90-degree plug/receptacle ends. Figure 21 is a schematic of the system cabling and connections from the Intellitec to the Shorepower pedestal.

Following the system diagram, connect the L1 and L2 lines of the short raw cable to the appropriate 50A main breakers on the distribution. Next, route the cable along the floor behind the underbunk area bulkhead to the driver's side compartment where the strain relief panel will be installed. The strain relief box should be mounted on a solid surface, preferably metal, on the inside of the bulkhead wall if possible. If this is not possible, mount the box so it is well

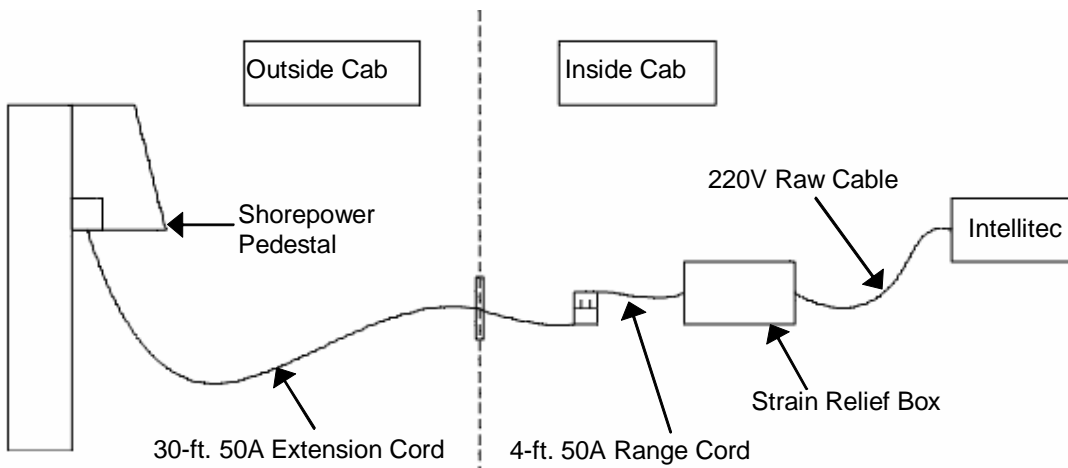

Figure 21: Schematic of on-board and off-board Shorepower cabling

protected from the driver and any items that may be placed in the compartment. Route the ends of the two cables into the strain relief box and use wire nuts to connect the ends. Tightly coil the 30' extension cable in the driver's side compartment.

Install the front panel on the Intellitec after all electrical connections are made. Figure 22 shows the completed installation of the Intellitec unit. The Intellitec installation manual has a set of tests that should be done to ensure the hardware is installed correctly. A full EMS system test should be performed after all hardware components are installed.



Figure 22: Completed installation of the Intellitec distribution panel

### ***Interior Electrical Outlet Installation***

The electrical outlets are part of the P&T Cab Power system designed for onboard power distribution. The outlets are surface mounted with two screws (FIG 23), and only require a small hole to be cut in the panel behind the outlet. This hole is used to pass the wire through (FIG 24) and to route back to the Intellitec. The outlet only has a short (approx. 6") length of wire, which ends at a quick-disconnect power connector. The quick-disconnect also allows easy replacement of the outlets or wiring if required. Several wires lengths for connecting the outlets to the Intellitec are available, minimizing unnecessary wires. The P&T Cab Power wiring is part of a system that has a 15A load center, which is not used in this installation because of the higher current demand of the components in the system being installed. The wires provided with the P&T Cab Power system have quick-disconnect fittings at both ends. However, to use these wires with the Intellitec, the connector at the load center end of the wire must be removed (cut off).

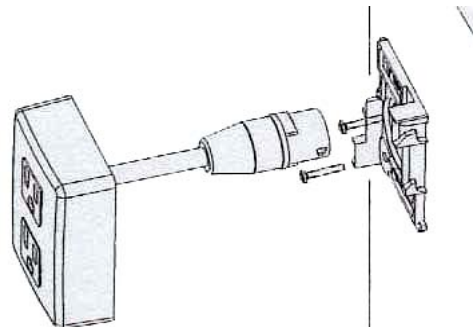

Figure 23: Cab Power electrical outlet mounting diagram

One consideration when selecting outlet locations is how the Intellitec system load shed order was arranged. For example, some accessories (e.g. refrigerator and television) may need power at all times, and should be connected to outlets which can be powered by the inverter. Because of this issue, two accessories (for example the refrigerator and microwave oven) may be installed next to each other, but must be connected to separate outlets. The outlets should be placed in logical locations throughout the cab. This will eliminate the need to have cords cross the drivers space and will reduce the chance of overloading an outlet. One 120VAC/15A outlet

must be mounted in the center underbunk storage area close to the HVAC unit. Figure 25 shows examples of electrical outlet surface mount locations.

The wires should be hidden as much as possible by running in wall creases, through cabinets, on the floor at the front of the underbunk area, and flush along surfaces as they are routed to the Intellitec (FIG 26). This provides a cleaner and more professional installation, and also minimizes the possibility that the wires can be damaged during use.



Figure 24: Inside of cabinet for electrical outlet mounting



Figure 25: Interior surface mounted electrical outlet locations

### ***Block Heater Installation***

If needed, the block heater outlet must be installed on the driver's side of the cab. The Shorepower system is designed to have all power and communication connections on the driver's side of the truck to keep the wires in the driver's line of sight. This improves the opportunity that onboard and land-side Shorepower hardware will be disconnected before the driver pulls out of

the parking space. Installing the block heater outlet on the driver's side may require an additional length of wire be spliced to the original wire in order to reach the driver's side, especially if the block heater is installed on the passenger's side of the engine. Route the wiring away from high temperature components like the turbocharger and exhaust manifold, and away from rotating components like belts and fans. Block heaters typically have a cord that is left dangling, or is restrained by zip ties to another component (FIG 27). A drive-off while connected may rip the cord out of the block heater, and may even damage other hardware or bodywork. A P&T Cab Power 120VAC power cord outlet is used for the block heater electrical connection. This P&T outlet gives additional cable length to route the cord to the driver's side, and the housing is designed to be rigidly mounted to the truck body. A rigid mounted receptacle allows for pull-out protection because the plug will pull out of the outlet rather than damaging the internal wiring.

The P&T receptacle has a spring-loaded weatherproof door on the housing and a 120VAC cable with male pins that snaps into the housing from the rear. The first step is to

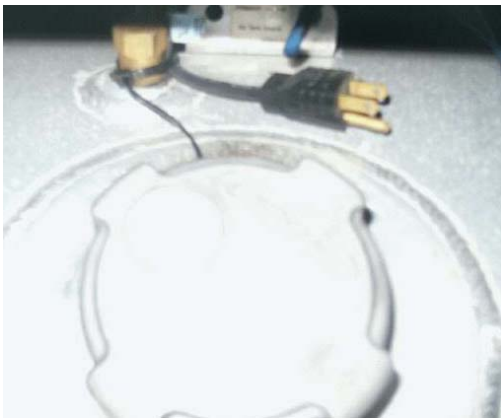

Figure 27: Standard loose block heater cord zip tied to passenger's side fuel tank

determine the mounting location. A good mounting location is on the driver's side step or front fender because it is close to the engine and will not be confused with the main Shorepower connection location. Figure 28 shows an example of an installed receptacle. Inspect the mounting area to make sure there is adequate clearance for the housing and wiring. Also, ensure that no structural beams, electrical lines, air lines, or other vehicle components will be damaged when the holes are cut and the screws are fastened. Use Template 2 located in the P&T installation manual (Figure 29 shows a smaller picture of the template) to mark the holes for the housing. Use a 1 3/4" hole saw to cut the hole for the housing. Use a #10 drill bit to make the four bolt holes. Place the housing through the hole so that the door opens upwards and the text on the door can be read. Secure the housing with four 10-32 Phillips

head screws, lock washers, and flat washers. The housing has a foam gasket, but a bead of silicone sealant can also be used if desired for additional protection. Insert the male, weatherproof end of the power cord into the receptacle and rotate until the spring loaded plunger pops into the hole, locking the cord in place. Figure 29 illustrates the mounting of the housing and attaching the cord.

### ***Exterior Weatherproof Receptacle Installation***

The standard location for the power and entertainment (TV/phone combination and Internet) cable receptacles is on the driver's side of the cab for reasons previously mentioned. The ideal mounting location is in front of the access door to the underbunk storage area, if there is enough space and clearance. The space behind the refrigerator, or storage area behind the driver, can also be used if clearance and access is adequate. The main power should be installed here



Figure 26: Semi-concealed electrical outlet wiring run

receptacles because of the location of the main 120/240VAC-50A cable installed earlier. Under most circumstances, however, there should be enough room in this area for the main power, Internet, phone, and cable TV receptacle housings. There is no required arrangement for the receptacles; however, a few guidelines should be followed. First, the main power connection must be at floor level in the storage area because of the landside extension power cord weight and the installation location of the main power cable. The second requirement is that the receptacle arrangement should be logical and as compact as possible for a clean and easy-to-use arrangement. Figure 30 shows an example of a completed installation of the television/phone (top), main power (middle), and Internet connections (bottom) next to the underbunk access door. Inspect the area for structural beams, cab wiring, air lines, and any other hardware before cutting the holes.



Figure 28: Phillips & Temro block heater outlet installed on driver's side step/fender

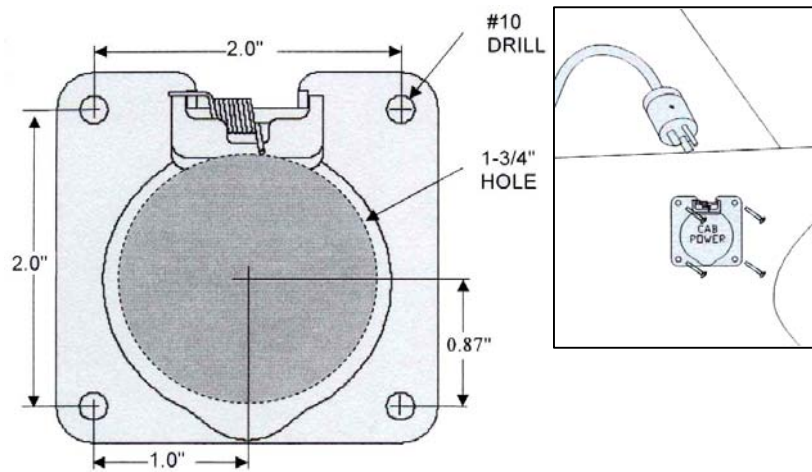

Figure 29: Phillips and Temro weatherproof housing (used for the block heater and telephone/cable TV connections)

The main power connection is not a rigid mounted receptacle because a proper surface mount plug receptacle, or standard for one, does not exist yet. A standard, hardwired 120/240VAC-50A RV cord is used instead. The cord was installed in a previous step, but an access door to the plug connection still needs to be installed. An RV locking electrical cable hatch is used as an access door (FIGS 30 & 31). The hatch lets the hardwired power cord to be connected to the land side power. The hatch door also enables the connection to be secured inside the truck for weatherproofing and increased safety. Many models/brands of locking hatches can be used. The hatch should have a small notch with a sliding door for the cable to pass through for the best protection from water intrusion. The hatch should be as small as possible, provided that the plugs fit through the opening. The instruction manual for the electrical hatch being used will give the proper size of the hole that needs to be cut. Mark the location of



Figure 30: Exterior Shorepower outlets (from top to bottom: TV/phone, main power, and Internet)



Figure 31: Close up of the locking RV electrical hatch used for the main power connection

the hole so the bottom edge is even with the storage compartment floor and cut it out with a reciprocating saw. Mount the hatch with screws (FIG 32). Use screws with screw heads that do not interfere with the hatch hinge. Apply a bead of silicone sealant around the outlet to seal the opening.

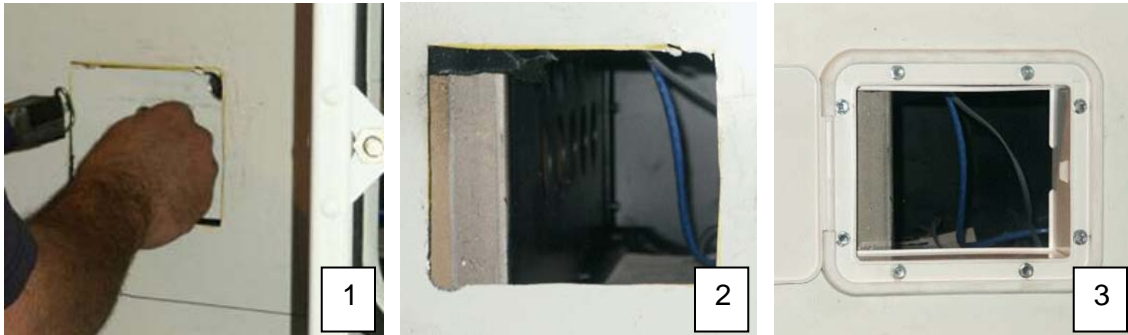

Figure 32: Installation of the locking electrical hatch for the main power connection

The cable TV/phone receptacle can be installed anywhere that is convenient. The housing is identical to the block heater housing (except the door cover reads “TV & Phone”). Use Template 2 located in the P&T installation manual (Figure 29 shows a scaled down picture of the template) to mark the holes for the housing. Use a 1 3/4” hole saw to cut the hole for the housing. Use a #10 drill bit to make the four bolt holes (FIG 33). Secure the housing with four 10-32 Phillips head screws, lock washers, and flat washers. The housing has a foam gasket, but additional silicone sealant can also be used if desired. The interior wiring will be routed and connected in the next step. This will not be a problem since the connector snaps into the housing from the rear the same as the block heater outlet.

The exterior Internet connection uses a standard household-type weatherproof exterior outlet cover and electrical box hardware (P&T does not offer an Internet connection receptacle with their Cab Power system). A customized approach may be used if a single wire jack connection/weatherproof door cannot be located. For example, an exterior weatherproof outlet cover can be stacked on top of a standard interior Internet wall plate.

Determine and mark the mounting location. The size of the hole depends on the design of the electrical box being used. Start the hole with a hole saw and finish with a reciprocating saw. Put the box in the hole and secure it with screws. The cable is standard RJ45 cable. Put the

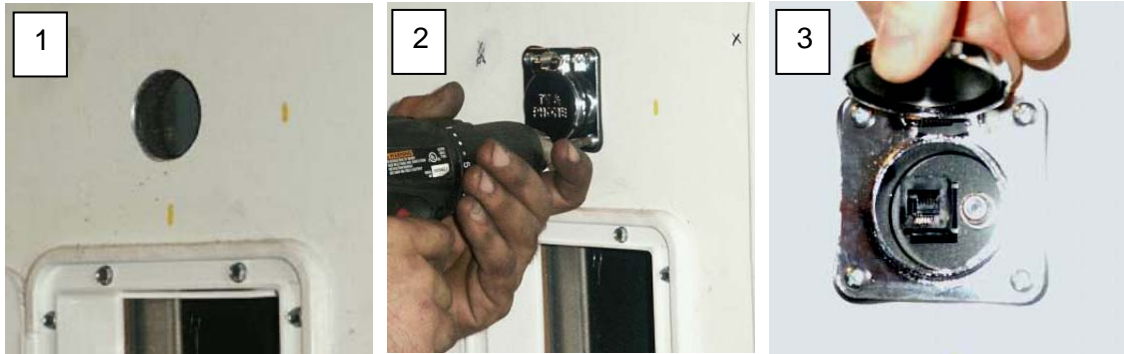

Figure 33: Mounting and installation of the exterior TV/phone outlet

RJ45 cable inside the truck and route one end through the electrical box. There are many different wall plate and jack designs, so the instructions from the manufacturer should be followed to make the connections. Secure the wall plate to the electrical box with screws. The exterior outlet cover has a spring-loaded door and weather stripping to protect the receptacle from rain and snow. The plate should either be oriented with the hinge facing upwards or towards the front of the truck. This will minimize the chances of the door opening due to wind resistance while the truck is driven, and rain, snow, and/or other road grime corroding the contacts. Apply a bead of silicone sealant around the outlet to seal the opening. Figure 34 shows the installation process (note that the outlet is not oriented properly in the Figure). Figure 35 shows a view of the electrical box



Figure 34: Internet connection receptacle installation



Figure 35: Interior shot of Internet electrical box installation

mounting from inside the vehicle. Note that the box is mounted in the space inside the wall, but is below the floor level. This is acceptable because the space was available, the wire is not exposed to the outside, and it did not affect the wiring or vehicle structure.



## **Entertainment Wiring Installation**

The first step is to determine where the entertainment components, such as the TV, telephone, computer, etc. will be installed. The exterior receptacle for the telephone and cable TV was installed in the previous step. The wiring for the TV and phone are combined in a cable assembly that snaps into the housing in the same manner as the block heater outlet. The cable assembly snaps into the housing from the rear so the interior wiring can be run before the receptacles are mounted on the outside of the truck (if necessary). Place the cable assembly in the under bunk area and snap it into the exterior housing from the rear. Route the cable TV and phone wires to the locations where the wall plates will be installed. The wires are not connected together along their length, so they can be routed to different locations. The Internet cable was connected to the exterior outlet in the last step, and the remaining cable was left coiled up in the storage area behind the outlet. Route the cable to the location where the jack will be installed.

The wall plates and electrical boxes are standard home products that can be bought from any hardware supply or home electronics store. Determine and mark the mounting locations for the different outlets. Start the holes with a hole saw and finish them with a reciprocating saw. Install the box in the hole and secure them with screws. Route the wires through their appropriate electrical boxes. Connect the wires to the jack on the wall plate. There are several different wire connection designs, so the instructions from the part manufacturer will have to be followed to make these connections. Several companies offer modular wall plates and jack products that allow for custom combinations, such as a cable TV and Internet jack using the same wall plate. Push the wire slack back through the hole and secure the wall plate with screws. Figure 36 shows the installation process for a combination telephone/Internet wall plate. Figure 37 shows the completed installation of the cable TV wall plate on the floor of the TV area.

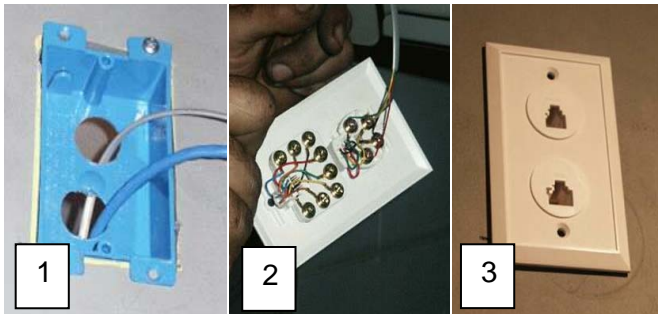

Figure 36: Installation of telephone/Internet combination wall plate



Figure 37: Cable TV wall plate mounted on floor of TV area

Hide and zip tie the extra cable length to make installation as clean as possible and to decrease the potential for damage. The 30' land-side connection wires should be bundled together, coiled up, and placed in the storage area.

## **External 120VAC Accessory Outlet Installation**

The system includes an exterior accessory 120VAC-15A outlet so the driver can use power tools, or can power the (120VAC) block heater if 240VAC service is used. An exterior grade residential ground current fault indicator (GCFI) outlet and a weatherproof exterior outlet cover with spring loaded door and water seal is used with standard stranded copper conductor available from any hardware supply store. Using stranded wire is important because it is not affected like standard solid core wire by the vibrations and motion that will occur while the truck is driving would be.

The outlet should be put in the same area as the previously installed exterior receptacles. However, if there is not enough space near those receptacles, it is acceptable to mount the outlet

on the rear of the truck. The outlet and wiring should still enter through the driver's side underbunk storage area for safety and accessibility reasons. This does not create a potential problem if the driver pulls out while connected because the outlet is not connected to the land-side system. Inspect the area for structural beams, cab wiring, air lines, and any other hardware before cutting the holes. Mark the location of the hole, use a hole saw to start the hole and finish it off with a reciprocating saw (FIG 38). Mount the electrical box with screws. Route the length of 120VAC wiring from inside the cab through the hole in the electrical box and connect it to the GCFI outlet. Push the wire slack back through the hole and fasten the outlet to the outlet box. Mount the weatherproof cover. Apply a bead of silicone sealant around the outlet to seal.

Route the 120VAC cable back to the Intellitec flush along surfaces to minimize potential interference/snagging when the driver uses items in areas through which the wire is routed. Connect the wires to the appropriate breaker in the Intellitec.

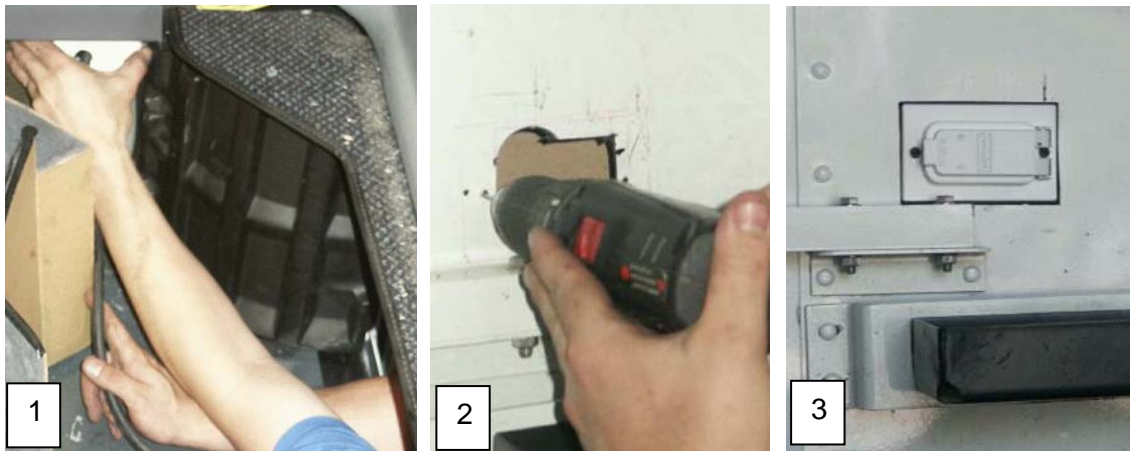

Figure 38: Installation of exterior accessory 120VAC outlet

## Accessory Installation

Each accessory is mounted differently depending on the unit's design. There are many models of each accessory (e.g. microwave) that can be used, so the directions from each manufacturer must be followed.

The TV area may have a buckling strap that can be tightened like a seat belt over the top of the TV to secure it. The RV industry has several mounting hardware kits for televisions that can be used to augment, or replace the "seat belt" mounting (FIG 39). One example of a TV mounting kit uses a set of straps to hold the TV down. One of these straps can be used with the "seat belt" (FIG 40). A set of clamps are secured to the walls of the TV area with screws. A strap is fed through the clamps and is tightened.

Space saver coffee makers (for example some Black and Decker models) are designed to be installed under a cabinet and are easier to mount in the cab than traditional counter top models. The overall shape is a rectangular block, which can also be easily mounted and secured either by hanging or on the base. Space saver models have hardware for mounting the coffee maker from above in the standard installation kit. Adhesive strips or brackets can be used to mount the unit on top of a surface. Kits with straps from the RV industry, similar to the TV mounting kit, for securing the coffee maker are also available. Figure 41 is an example of a space saver coffee

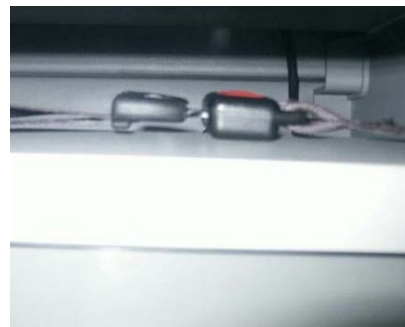

Figure 39: TV secured on top with "seat belt"



Figure 40: TV secured with mounting strap

pot mounted on top of the cabinet behind the driver using RV-type TV straps to secure the unit and a coffee pot strap to hold the carafe in place.

The refrigerator choices are very limited due to the limited space in the cab. The truck should have an opening designed for a refrigerator. If such a space is absent, installing a refrigerator may not be possible. Tundra makes a wide range of refrigerator sizes, including some very small models designed for small spaces in trucks. Tundra is the only manufacturer that currently manufactures refrigerators designed for truck sleeper cabs. Other manufacturers and models can be used as long as they fit the opening. The refrigerator model shown runs on 12VDC power and requires the optional 120VAC/12VDC inverter. This allows the refrigerator to plug into a 120VAC outlet



Figure 41: Space saver coffee pot mounted with RV-type securing straps

and be controlled by the Intellitec. Figure 42 shows the installation of the 12VDC-120VAC inverter. Figure 43 shows the refrigerator being mounted.

The microwave can be mounted any place there is space. Typically sleeper cab trucks have a space underneath the overhead storage compartment on the driver's side designed both for space and strength to accommodate hanging a microwave. Space saver type household microwaves from companies like GE, or models designed for trucks and RVs such as the Dometic Corporation model (shown in Figure 44), must be used because of their size and

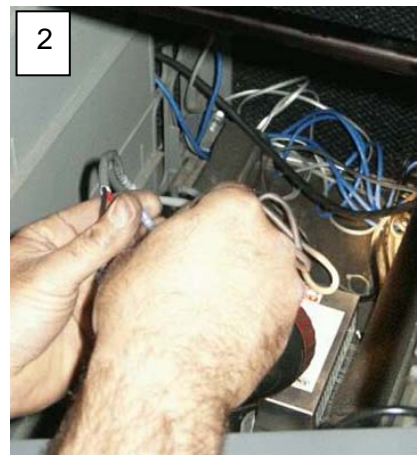

Figure 42: 12VDC-120VAC refrigerator inverter installation

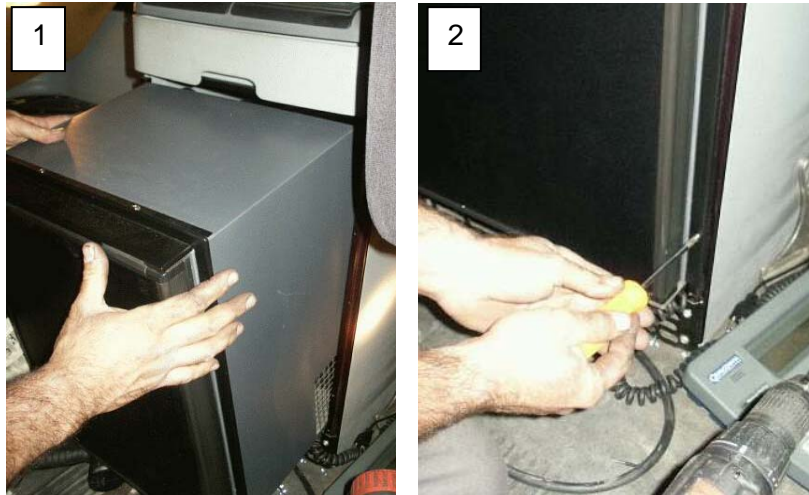

Figure 43: Refrigerator mounting



Figure 44: Microwave installation

can be mounted with the mounting brackets. installation manual for complete metal brackets inside the cabinet that in the cabinet following the manufacturer's the brackets from inside the cabinet.

Read and follow the manufacturer's specific instructions. The microwave is bolted to two properly distribute the weight. Drill the holes instructions and bolt the microwave oven to

### ***Final Electrical System Wiring***

All of the interior and exterior 120VAC outlets, the 120/240VAC-50A main power cable, and the inverter should be connected to the appropriate circuit breakers in the Intellitec.

However, if all of the connections have not been completed yet, make them now following the Shorepower wiring diagram. Remember to use the correct breakers on the Intellitec to ensure proper load shed order. **Double check that all wires inside the distribution panel on the circuit breakers, neutral strips, and ground strips are securely tightened.** Check all outlets to ensure they are securely wired to the correct breakers. Figure 45 shows the completed wiring of the Intellitec. Check that the Intellitec board is properly connected to the 12VDC power source and the correct polarity. Make sure that the Cab Comfort HVAC unit has the 12V ignition interlock (only powered when the key is on) wiring properly connected. Check that all the remote panel wires (Intellitec, inverter, and HVAC) are connected.



Figure 45: Completed Intellitec wiring (cover was removed for picture)

Inspect all of the wiring and use cable loom or wire ties on any remaining loose/extra wiring (FIG 46). Check the quick-connects on the P&T outlets and wiring to ensure all are fully seated and flush against the walls, or are hidden.

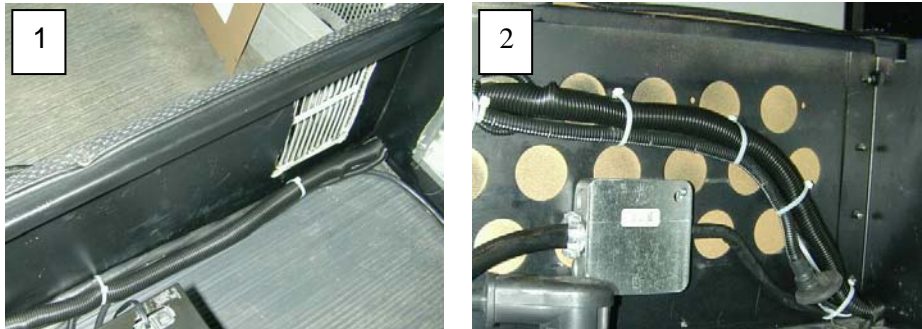

Figure 46: Cleaning up cable runs with wire ties and wire loom

## System Tests

Testing should be done starting at a component level to make sure each part is working properly before testing the whole system.

### Xantrex Inverter Testing

The inverter and remote panel operation manual should be read first to learn how the inverter and remote panel work. The first test that should be performed is the inverter functionality when disconnected from Shorepower. Connect an AC output from the inverter directly to an AC load (such as one of the 120VAC outlets with a test light connected to it). The inverter is already connected to the truck battery, and should automatically begin inverting the DC power to AC to power the test load. If the test light turns on then the inverter is functioning properly. If it does not light, check the connections and consult the inverter installation manual for troubleshooting tips.

The inverter has an AC bypass circuit that bypasses the hardware circuitry to form a straight through power path when connected to an AC power supply. To test that the AC bypass

is functioning properly, connect the inverter AC input directly to a 120VAC wall outlet. The 120VAC outlet and test light used in the previous step are used again. If it does not light, check the connections and consult the inverter installation manual for troubleshooting tips. Reconnect the test outlet to the Intellitec once it is determined the inverter is functioning properly.

Test that the various inverter features using the remote panel, such as the battery voltage readout, the battery charge, invert all function properly following the instructions in the manufacturer's installation manual. Refer to the inverter installation manual for troubleshooting tips to determine the cause and resolution of common problems.

## **Intellitec Testing**

As a reminder, the Intellitec EMS Control Module board is disabled unless it senses 120VAC or 240VAC power, and the control board has 12VDC power with the proper polarity. The 12VDC line must be powered at all times; the system does not draw supply power from the battery unless 120VAC/240VAC is connected.

The test procedure is fully detailed in the installation manual and should be read before proceeding. The first step is to disconnect the Shorepower connection if one was made prior, disconnect the 12VDC power line for the EMS Control Module, and make sure all 120VAC loads are disconnected. Connect both the 12VDC and the 120VAC Shorepower connection lines. You should hear the relays on the Control Module board close. The numeric display on the remote control display panel should read "0" since no loads are connected. The six Power Status LEDs and the "30-Amp" Service Type LED should all light up. A clamp-on ammeter should be used to verify the system is measuring the current use properly. Connect and turn on one of the AC loads connected to one of the controlled AC outlets. The load should then be powered and the Intellitec EMS display panel should display the real-time current draw. Verify the reading with the clamp-on ammeter. Turn the load off and repeat the process with the remainder of the controlled and uncontrolled AC loads.

To test the load-shedding feature, turn on all of the controlled loads. Add loads to uncontrolled outlets to force the current demand to be greater than 30A if the current draw is not above 30A. Loads should shed according to the shed order. If this does not happen, disconnect the loads, verify the electrical connections and jumper settings on the EMS Control Module, and retest the system. If the problem persists, review the troubleshooting guide in the installation manual. Contact the Intellitec technical support line for any unresolved problems.

A 240VAC Shorepower line test is next once the 120VAC inverter tests (see previous section) are completed. Note: As a safety precaution, the 240VAC test cannot be done using two 120VAC lines connected together because the Control Module board requires that the two 120VAC legs be out of phase; the EMS Control Module will not power up if this is the case. Repeat the test procedure performed during the 120VAC testing. The load-shed feature is disabled when 240VAC is connected, so no load-shedding should occur; if it does, this indicates a problem. If load shedding does occur, disconnect the loads, verify the connections and retest the system. If the problem persists, review the troubleshooting guide in the installation manual. Contact the Intellitec technical support line if the problem remains unresolved.

## **Convenience/Entertainment Accessory Testing**

Connect the Shorepower line (120VAC or 240VAC), as well as the cable TV, Internet, and phone connections. The inverter should not be used at this point to power anything since power quality issues may prevent proper troubleshooting. Make sure that the display on the Intellitec is powered and displaying the current draw. If it is not, determine the cause of the problem and correct it before continuing. Plug in the coffee pot and turn it on to test operation. If it does not turn on, plug it directly into an extension cord from a 120VAC extension cord from a

wall outlet to make sure the problem is not with the coffee pot. Repeat the procedure with the microwave oven.

A DVD or video tape should be used initially to test the TV if one is available. This will eliminate erroneous problems if the cable signal is poor. Follow the TV operation instructions to turn on the TV and to load and play the DVD/video tape. If the picture is not acceptable, follow the manufacturer's troubleshooting steps. If the picture quality from the DVD/video tape is fine, then test the cable signal by connecting the television to the cable TV wall plate jack and turning on the television to a channel carried by the cable TV provider. If the channel comes in clearly, the TV and cable TV connection are connected properly. If there is no signal, check that the exterior cables from the land-side are tightly connected. If possible, connect the Shorepower cable TV extension directly to the television. This will determine if there is a problem with the Shorepower TV cable. If this does not correct the problem, then check the onboard P&T cable wiring kit. Check that the wiring connection is tight at the cable TV wall jack. Refer to the P&T Cab Power installation manual if this does not fix the problem. Call the Phillips and Temro technical support line if this does not resolve the problem.

Test the Internet connection using a laptop computer. Change the network card settings (IP address, gateway, etc.) to match the network's and test the connection using a functioning Ethernet (RJ45) jack in the or service bay, or office. Open a web browser window (Microsoft IE, Netscape Navigator, etc.). After the homepage loads, hit the "refresh" button. Hitting "refresh" is necessary because this forces the computer to download the web page data again to ensure that the webpage is being downloaded, rather than loading a cached page. If this works, then there is no problem with the computer hardware or network card settings. The next step is to test the Internet connection using the Shorepower Internet extension cable. Connect the laptop to the end of the cable and hit the "refresh" button. If it does not load properly, then there is a problem with the Shorepower Internet extension cable. If the page refreshes, move to the next step. Connect the Shorepower Internet extension cable to the exterior Internet jack and connect the computer to the jack inside the cab. Hit the refresh button again. If the page loads fine then the wiring is properly connected. If the page does not load, then a problem exists within the wiring onboard the truck. Check the connection of the individual wires at both ends of the Internet cable. Reconnect any loose wires. Retest the connection. If this does not fix the problem, the onboard Internet cable may be damaged and may need to be replaced.

Test the phone connection by plugging a functioning phone into a functioning phone jack in the service bay or office and listen for a dial tone. If there is no dial tone, the cable is damaged and needs to be replaced. If there is a dial tone, then connect the phone to the end of the Shorepower phone line and listen for a dial tone again to ensure the Shorepower phone cable works properly. If there is no dial tone, the Shorepower phone cable is damaged and needs to be replaced. If it does work, then plug the Shorepower phone extension cable into the exterior phone jack on the truck. Plug the test phone in the interior jack and listen for a dial tone. If it works, then the system test is complete. If there is no dial tone, then there is either a problem with the wiring itself, or with the connection of the wiring to the wall plate. Check the wire connections and retest the line. If it does not work, contact the Phillips and Temro technical support line for help.

There may be an issue with running the TV off of the inverter because the inverter does not supply a perfect sine wave output like a regular AC outlet. The TV was tested using Shorepower AC power earlier, so now it must be tested using inverter AC power. Disconnect the Shorepower line and plug the TV into an outlet that is powered by the inverter when Shorepower is not connected. Turn on the TV and play the DVD. If the picture quality is fuzzy, or odd in another way with either the TV or DVD, the problem is a result of the inverter power quality output. Nothing can be done to fix the problem since it is related to the inverter's normal operation. Running the TV off the inverter will not damage the TV; the picture quality will only suffer. The problem will only be present when the TV is operating off of the inverter.

## **Appendix 1: Example Shorepower Equipped Vehicle Wiring Diagram**



# Vehicle Wiring Diagram

Body, 110 Volt System

Exterior Panel

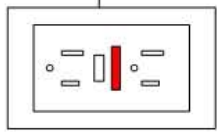

120 V Exterior Power Supply

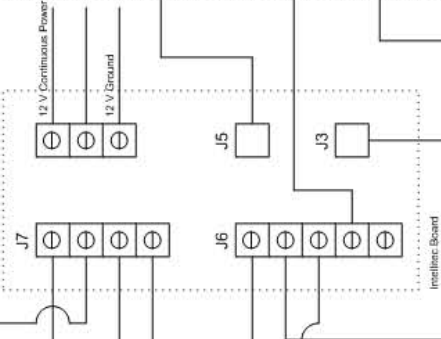
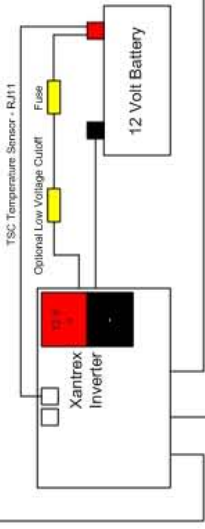
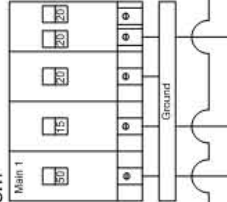
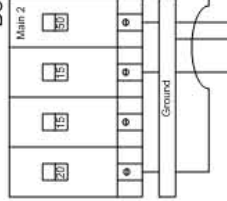
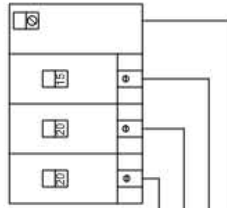

Sleeper Cab

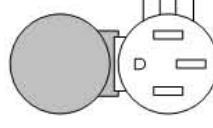
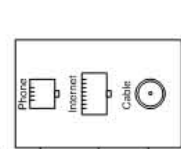
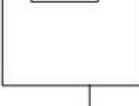
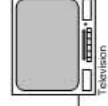
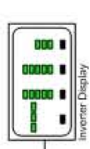
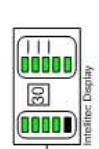

Exterior Power Supply Input

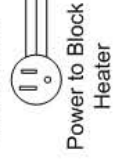

Power to Block Heater

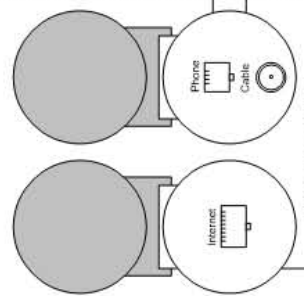

Entertainment Supply Input

Ground  
L2  
L1  
Neutral

Block Heater

Current Sensor Cable



Insulated Neutral

Phone Line

Cowled Cable

Curr 5 Cable

**APPENDIX C – WILTON EMPLOYEE FACT SHEET**



# Reducing Idling at Truck Stops

## I-87 Northway Shore Power Truck Stop Electrification Demonstration

### What is Truck Stop Electrification?

Truck Stop Electrification, also referred to as TSE, is a relatively simple concept: instead of idling truck engines during mandated rest periods, truck drivers can connect to a service unit that provides power for their comfort and work needs. TSE systems provide power for heating or cooling the sleeper compartment, electricity for personal appliances and in some cases, phone service, cable television and Internet access.

### Why is this Important?

Thousands of long-haul trucks travel the Northway (I-87) every day in New York State. When drivers stop for rest periods, they often have little choice but to leave their engines running to provide power for basic comfort items such as heat and air conditioning and to maintain battery power for other systems. Idling increases fuel costs to truckers, adds wear and tear on the engine and increases overall transportation costs. It also creates diesel emissions which are known to be harmful to human health and CO<sub>2</sub>, a global warming contributor. Reducing idling with technologies such as truck stop electrification (TSE), is a “win-win” for truck drivers, truck stop operators and the community as a whole.



### What is Shurepower?

Shurepower supplies electricity and telecommunication services to truck stops and travel plazas through multi-service pedestals (MSPs), shown above.

Shurepower’s MSPs provide drivers with electrical power (shore power), cable television, local phone service, and Internet connections.

In the near future, drivers will be charged a nominal fee (\$0.75-\$1.00) to use the MSPs, but during this demonstration period, Shurepower services are being offered for free.

The Shurepower system also includes a payment/control system (also shown in the picture above) that allows drivers to activate the MSPs. Drivers simply “swipe” the user card and enter the MSP stall number they wish to use.



### TSE Demonstration Project at Wilton Travel Plaza

The New York State Energy Research and Development Authority (NYSERDA), through a competitive contracting process, awarded Antares Group Incorporated a contract to install and monitor the shore power TSE demonstration project at the Wilton Travel Plaza. The system hardware is now maintained and upgraded by Shurepower, LLC.

### What are the benefits of this Demonstration Project?

Drivers using Shurepower’s MSPs will benefit from the following:

- Lower fuel costs
- Lower service and maintenance costs
- A better night's rest
- Improved air quality and health

#### Contacts:

**24-hour System Information and Support**  
Toll-Free:  
1-866-232-0155  
[www.shurepower.com](http://www.shurepower.com)

**New York Office**  
153 Brooks Road  
Rome, NY 13441  
Phone: (315) 404-5613  
Fax: (315) 838-4877  
Contact:  
Mike Panich  
[info@shurepower.com](mailto:info@shurepower.com)

**West Coast Office**  
6115 SW Dolph Drive  
Portland, OR 97219  
Phone: (503) 892-7345  
Contact:  
Jeff Kim  
[jkim@shurepower.com](mailto:jkim@shurepower.com)

**Project Management Antares Group**  
4351 Garden City Drive  
Suite 301  
Landover, MD 20785  
Phone: (301) 731-1900  
Contact:  
Jean-Paul Tait  
[jtait@antares.org](mailto:jtait@antares.org)  
[www.antares.org](http://www.antares.org)



Wilton employees and the community will benefit from:

- Lower noise levels
- Improved air quality and health
- Safer roads from well rested and more alert drivers

### Who can connect?

Any truck can connect by simply using an extension cord to power any on-board 120/208VAC appliances such as an electric heater, microwave oven, television or radio. Any driver that has a laptop computer or television can connect to the MSP with a regular CAT5 ethernet cable or coaxial cable respectively.

Most long-haul trucks already have a block heater connection that can be plugged into the MSP. Currently, one in twelve trucks are equipped with shore power connections and on-board electric heaters. Aftermarket shore power connect kits are available for sale now in the convenience store and on-line at [www.shurepower.com](http://www.shurepower.com). The connect kits come with the necessary material to install shore power on a truck and also come with an electric heater to provide comfort during moderately cold weather. Shurepower encourages the Wilton Travel Plaza employees to inform the truck drivers about these connect kits and will provide a \$10 incentive to the employee for each kit they sell. If truck drivers are interested in the shore power kits with an air conditioning unit or additional upgrades please direct them to our website or have them call toll-free 1-866-232-0155.

### How Can I Help?

As an employee for one of the largest travel plazas in the region, you should take pride in the fact that the Wilton Travel Plaza has taken steps to improve environmental and living conditions for drivers, employees, and the community, by installing Shurepower equipment at the truck stop.

We ask that you provide information to educate drivers about this new shore power TSE technology. This may also include answering any questions they may have about the Shurepower system and providing them a brochure explaining the system. We also ask that you encourage

drivers to use the system, which is free for their use for a limited time. In addition, we request that each driver using the system complete a one page sign-up form prior to receiving a Shurepower user card.

### MARKETING CONTEST

For the months of December and January, Shurepower is providing incentives to Wilton Travel Plaza employees to help us market this service. Every time you help someone sign up for a Shurepower User Card, write your name on one of the Employee Incentive Cards and staple it to the sign-up form after you fax the form to Shurepower at (301) 731-1904. Each card has a space for one fuel pump employee and one store counter employee. Shurepower will award a prize to each type of employee in both December and January. For both months, the person from each category who signs up the most people will win \$250.



### How Can I Get More Information?

For more information about the project, call Jean-Paul Tait at (301) 731-1900 extension 19 or visit [www.shurepower.com](http://www.shurepower.com).

For drivers interested in connecting to the services, or for technical questions, call toll-free 1-866-232-0155.



**APPENDIX D - IDLE REDUCTION TECHNOLOGY  
COST COMPARISON**

# Idle Reduction Technology: Cost Comparison

## Plug Into Savings



Heavy-duty truck idling increases driver and fleet expenses through higher diesel fuel costs, engine and component wear, and maintenance costs. Additionally, engine idling creates unnecessary exhaust emissions and noise, can be harmful to driver health, and may result in poor quality rest periods.

Many idle-reduction technologies have the potential to save drivers and fleets thousands of dollars per year. Truck stop electrification (TSE) provides the driver with grid-based power and may include other amenities such as cable television, Internet and phone connections. Power connections are used for heating, ventilation and air conditioning (HVAC) systems, televisions, DVD players, computers, coffee makers, microwaves, power tools and lights.

Currently there are two different types of TSE. Shurepower TSE is very similar to shore power technologies used at marinas and recreational vehicle parks. Shurepower TSE focuses on providing electricity for on-board convenience appliances.

On the other hand, "off-board" TSE does not require the driver to have any equipment other than a \$10 window template. However, the on-site infrastructure costs are greatly increased in order to effectively provide HVAC and ancillary services.

Another alternative is an auxiliary power unit (APU) system that is completely mounted on the vehicle; therefore, they can be used independently of any land-based connection. However, auxiliary power equipment is more expensive and heavier than TSE equipment, thus taking away from the revenue producing capacity of the trailer load. These systems cannot provide other services such as cable television and Internet. In addition, most APUs use a small engine to provide heat, cooling and electricity; therefore, they generate a significant amount of local emissions and noise.

Savings that will accrue to users of non-idling energy technologies are specific to a number of variables including individual usage patterns, average annual idling hours avoided, diesel fuel prices, and fuel consumption rates. In this comparison, Shurepower TSE, off-board TSE and an APU system are compared for relative cost savings to the end user using a common set of assumptions that are based on average industry data.

All the listed idle-reduction technologies have the potential to improve fleet profits. Depending on driver utilization patterns and the idling characteristics of the vehicle, Shurepower is the least expensive idling alternative available today.

### Initial Capital Investment

Shurepower – Basic Connection .....	\$189
Shurepower – with electric HVAC .....	\$2,500
APU .....	\$7,500
Off-board TSE .....	\$10

### Hourly Costs (Does not include capital cost)

Shurepower TSE .....	\$1.00
APU (fuel & maintenance).....	\$0.60
Off-board TSE .....	\$1.88

### Other Assumptions for Calculations

Diesel fuel cost .....	\$2.50/gal
Idling fuel consumption rate <sup>1</sup> .....	1.0 gal/hr
APU fuel consumption rate .....	0.2 gal/hr
APU Maintenance interval <sup>2</sup> .....	500 hours
APU Maintenance cost .....	\$50 each
Idling hours per year <sup>1</sup> .....	1,800 hrs
Lifetime/Investment cycle .....	5 years

### Total 5-year Costs

<b>Shurepower – with electric HVAC.....</b>	<b>\$11,500</b>
APU .....	\$12,900
Off-board TSE .....	\$16,930
Idling .....	\$22,500

### Total 5-year Savings

<b>Shurepower – Basic + HVAC .....</b>	<b>\$11,000</b>
APU .....	\$9,600
Off-board TSE .....	\$5,570
Idling .....	\$0

### Total Average Hourly Cost

<b>Shurepower – with electric HVAC.....</b>	<b>\$1.28</b>
APU .....	\$1.43
Off-board TSE .....	\$1.88
Idling .....	\$2.50

Calculations do not consider engine wear, service and maintenance, or parts replacement due to engine idling. The residual value of on-board components was also not considered. The above two factors would increase the overall savings from idle-reducing technologies and decrease payback times. Calculations also assume all technologies could be used 100% of the time. Off-board TSE and Shurepower include basic cable television and Internet services which is not included when using APUs or idling. The greatest overall savings can be achieved with Shurepower's services.

<sup>1</sup> Averages from UC Davis Driver Survey Study

<sup>2</sup> Willis Auxiliary Power System

## **APPENDIX E – ANL IDLING POSTER**

# Comparing Emissions Benefits from Regulating Heavy Vehicle Idling

Linda Gaines, C.J. Brodrick, Argonne National Laboratory  
David C. Orr, Caterpillar

## BACKGROUND



Numerous states regulate long-duration diesel engine idling as a way to reduce emissions and improve air quality. What impact do those regulations actually have on emissions, and how do they affect adoption of idling reduction (IR) technology?

Current idling regulations are inconsistent from state to state; some proposed regulations could further increase these disparities and impede implementation of IR technology.

This study compares the potential air quality benefits from such regulations as a function of regulatory limits and exemptions.

## COMPARISON OF EMISSIONS FROM IDLE REDUCTION EQUIPMENT

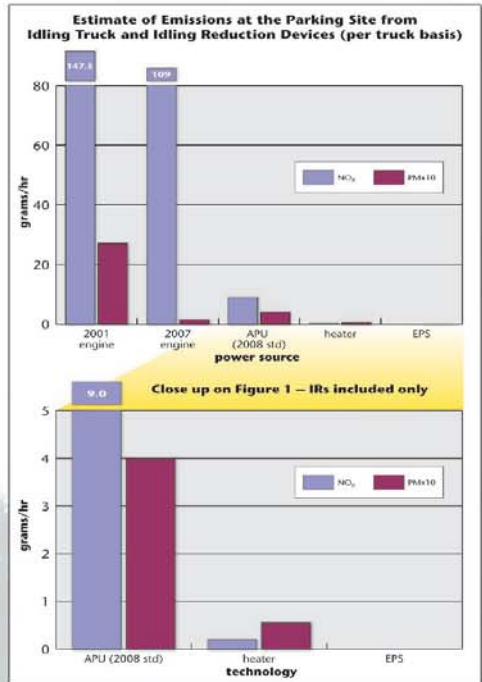

## ASSUMPTIONS

The current analysis assumes the following:

- Cab comfort devices were assumed to operate 7 hours/day, 303 days/year, except for the heater, which runs 150 days/year.
- Heater and current truck idling emissions and fuel consumption were derived from EPA (Lim, 2002) measurements, assuming 50% air conditioning and 50% heat.
- Emissions from 2007 engines were based on California Air Resources Board's estimates (CARB ISOR, 2003), as no measurements are available. Fuel consumption was assumed to be 5% greater than current trucks' due to emissions control equipment.
- APUs are expected to surpass 2008 standards when 2007 trucks are introduced; PM emissions were assumed to be 50% of the standard, in keeping with current surpassing of standards. NO<sub>x</sub> emissions were assumed to be 60% of the combined NO<sub>x</sub> + hydrocarbon (HC) small-engine standard. Fuel consumption was derived from measurements of a Caterpillar APU. Addition of a DPF was anticipated to reduce particulate matter (PM) emissions by 90%.
- Total energy cycle impacts were generated by adding the direct emissions and energy consumption to the impacts from producing the diesel fuel burned, as calculated from the Argonne GREET (Greenhouse gases, Regulated Emissions, and Energy use in Transportation) model. Similarly, impacts from electricity generation were estimated from GREET, for both US average and California generation mixes.

## IDLING REGULATIONS TODAY



## RESULTS

**Idling reduction (IR) devices:** All of the idling-reduction options enable significant reductions in energy use and all emissions compared to idling of current trucks, and also compared to 2007 trucks except for PM (see discussion at right). There are pros and cons for each type of device considered here. Heaters offer the lowest impacts but do not supply all cab comfort services. Auxiliary power units (APUs) supply all necessary services and can be used anywhere, any time the driver needs them. Electrified parking spaces (EPS) have zero impacts at the parking location, and most of their life cycle impacts are below those of the APUs because electricity generation at a large power plant is almost twice as efficient as it is in the APU (17 vs 31%). In addition, almost no power plant energy is in the form of oil. But parking must be restricted to equipped spaces, and there are economic problems getting that infrastructure (and any needed on-board equipment) in place. The first market for EPS use is likely to be for fleets with fixed routes.

**Regulatory impacts:** A sleeper exemption, would, of course, result in no reduction in the significant impacts from overnight idling. A temperature cutoff, below which trucks would be permitted to idle, would reduce sleeper impacts, but would compromise driver comfort when the temperature is just above the cutoff. We show the impact of a cutoff that would allow idling about 50 days per year (assumed to be 30°F for a moderate climate zone). If a locality instituted a short-time (e.g., 30-minute) exemption, sleeper impacts could be reduced more, but with potentially severe driver comfort issues. A timed exemption would enable significant idling during the course of the work day. On the whole, it appears that use of IR devices offers greater potential for reduction of long-duration than do regulatory approaches. Therefore, incentives to encourage purchase of IR equipment should be seriously considered.

Total Energy Cycle Annual Emissions and Energy Use for 1 Truck

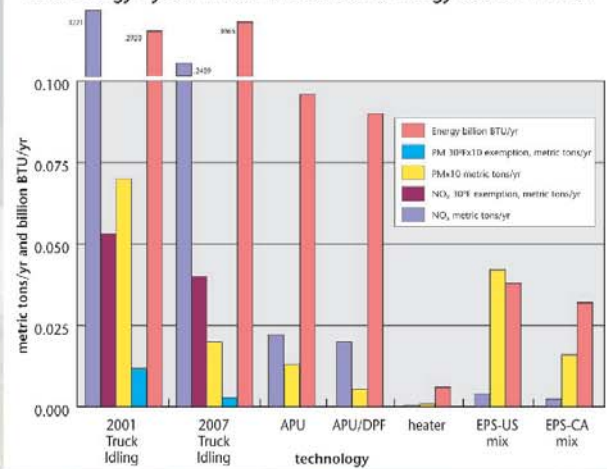

### Particulate matter (PM)

There is special concern because PM from diesel exhaust has been declared to be an air toxic. PM emissions for all of the IR devices are much lower than those from idling current engines. However, PM emissions from APUs and from EPS may be somewhat higher than from idling 2007 engines. Although no data are available yet on 2007 engine idling emissions (or on any engines running on ultra-low sulfur diesel), the Air Resources Board in California has proposed a regulation that would require particulate filters or other control measures on the small engines used in APUs for use on post-2007 trucks. Such a measure can be seen to produce minimal benefits, and could inhibit APU installation in cross-country trucks, resulting in higher impacts nationally. Furthermore, cost and regeneration issues for the APU DPF need to be addressed.